

Product Information Material Handling Machine

LH 18 M Industry

Litronic®

Generation

6

Operating Weight

17,000 – 18,000 kg*

Engine

105 kW / 143 HP

Stage V

Stage Tier 4f

* Without attachment

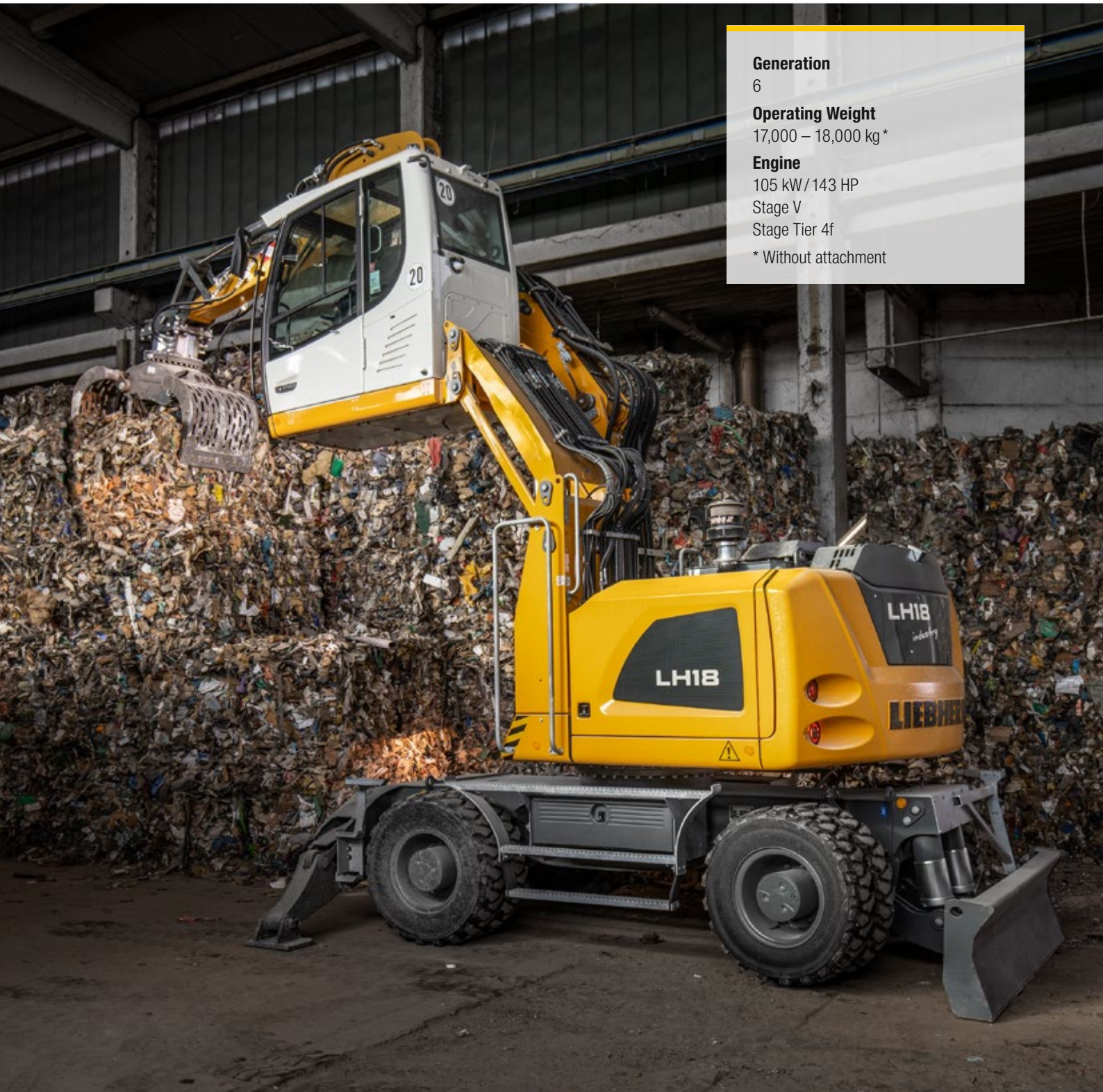

LIEBHERR

Performance

Power Plus Speed –
Redefined Performance

Economy

Good Investment –
Savings for the Long-Term

Operating Weight

17,000 – 18,000 kg*

Engine

105 kW/143 HP

Stage V

Stage Tier 4f



* Without attachment

Reliability

Durability and Sustainability –
Quality Down to the Last Detail

Comfort

Perfection at a Glance –
When Technology is Comfortable

Maintainability

Efficiency Bonus –
Even with Maintenance and Service



Well Thought Out to the Last Detail





Extremely Dusty Jobs

- Reversible fan slows down the accumulation of dirt in the engine and radiator, guaranteeing high levels of machine availability
- Protective grille with fine mesh, extending and folding fan for quick and easy cleaning
- Air pre-filter with dust discharge for extra-fine filtration of the engine intake air



Maintainability

- Stabiliser blade requires no maintenance
- All daily service points are accessible from the ground



Integral Travel Drive Protection

- Travel engine and gear unit are integrated in the robust undercarriage frame
- Robust design for toughest requirements

Convincing in Operation



Performance

Sensitive Hydraulics

The optimal harmonisation between the engine and the control valve allows a fast and direct response from the hydraulics to the input command. This is controlled proportionally to enable smooth and gentle movements to be executed when the joystick is moved.

Firm and Stable Positioning

An essential prerequisite for precise working and maximum handling capacity is the firm and stable positioning of the machine. The design of the Liebherr undercarriage optimises the way forces are induced on components to minimise stress and guarantee maximum stability and durability.

Economy

Sensor Controlled Low Idle Automatic

The time-tested standard sensor controlled low idle automatic reduces the engine speed to idling level as soon as the operator takes his hand off the joystick which means that no hydraulic functions are activated. In addition to saving energy, this also reduces noise.

Rapid Work Cycles

The elaborate machine controls guarantee that the hydraulics are optimally configured for the task at hand. Here, the load sensing control ensures that the flow delivered by the pump is optimally distributed when movements overlap. Speed and power are available whenever they are needed and thus ensures high handling capacity.

Road Licensing

The LH 18 M Industry with an adjustable boom package and the appropriate machine configuration can be issued with a road licence ex-works by the TÜV. This road licence enables it to work at the side of the road and to be driven to nearby places without the requirement for a special licence.

Reliability

Quality and Competence

Our experience, understanding of customer needs and the technical implementation of these findings guarantee the success of the product. For decades, Liebherr has been inspirational with its extent of production and system solutions. Key components such as the diesel engine and electric motors, electronic components, slew ring, slew drives and hydraulic cylinders are developed and produced by Liebherr itself. The extend of in-house manufacturing guarantees maximum quality and ensures that components are optimally configured to each other.

Robust Design

All steel components are designed and manufactured by Liebherr. High-strength steel plates configured for the toughest of requirements result in high torsional stiffness and optimum absorption of forces induced for a longer service life.

Working Area Limit

The handling machine can be fitted with an optional working area limit for jobs which require a limited working area. Every possible dimensional can be adjusted for this purpose – height, depth, reach and proximity. This can prevent collisions and the resulting component damage.

Requirement-Controlled Cooling

The vanes of the fan are driven regardless of the diesel engine, generating the exact cooling output that is actually required. Thermal sensors guarantee reliable, need-based and efficient control.

Comfort

Ergonomic

The latest cab design delivers excellent conditions for healthy, highly concentrated and productive work in maximum comfort. Both the display unit with touchscreen colour display, the controls and Comfort driver's seat are all coordinated to form a perfect ergonomic unit. In addition the ergonomic joysticks allow the machine operation to be both pleasant and precise.

Joystick Steering and Stabilizing

The standard joystick steering gives the operator an additional comfort boost. The steering movement can be conveniently executed using the joystick, eliminating the need to reposition during the work cycle. Substituting the steering wheel in favour of joystick steering provides additional legroom and a clear view of the working area. A new standard feature is Joystick control of the outriggers for more convenience and an increased productivity.

Proportional Control System

Precision and the fine control of the material handler are particularly important for applications such as material sorting or scrap recycling. The machine can master this demanding work with ease thanks to its standard proportional control system.

Maintainability

Service-Based Machine Design

The service-based machine design guarantees short maintenance times, thus minimising maintenance costs due to the time it saves. All the maintenance points are easily accessible from the ground and easy to reach due to the large, wide-opening service doors. The enhanced service concept places the maintenance points close to each other and reduces their number to a minimum. This means that service work can be completed every more quickly and efficiently.

Integral Maintenance Benefits

The completion of maintenance work helps keep the machine fully functional. Maintenance work does, however, mean machine down times which must be minimised. Automatic central lubrication systems for the uppercarriage and equipment as well as optional systems for the undercarriage, rapid change systems and attachments not only make it easier to adhere to the prescribed lubrication intervals and ensure a long service life for the components, but also increase the productivity of the Liebherr LH 18 M Industry handling machine.

Technical Data



Diesel Engine

Rating per ISO 9249	105 kW (143 HP) at 1,800 RPM
Model	D924 – FPT motor designed for Liebherr
Type	4 cylinder in-line
Bore/Stroke	104/ 132 mm
Displacement	4.5 l
Engine operation	4-stroke diesel Common-Rail turbo-charged and after-cooled reduced emissions
Air cleaner	dry-type air cleaner with pre-cleaner, primary and safety elements
Engine idling	sensor controlled
Electrical system	
Voltage	24 V
Batteries	2 x 135 Ah/ 12 V
Alternator	three-phase current 28 V/ 140 A
Stage V	
Harmful emissions values	according to regulation (EU) 2016/1628
Emission control	Liebherr-SCRT technology
Fuel tank	250 l
Urea tank	46 l
Stage Tier 4f	
Harmful emissions values	in accordance with EPA/CARB-40CFR stage Tier 4f
Emission control	Liebherr-SCR technology
Fuel tank	250 l
Urea tank	46 l



Cooling System

Diesel engine	water-cooled compact cooling system consisting cooling unit for water, hydraulic oil and charge air with stepless thermostatically controlled fan, fans for radiator cleaning can be completely folded away
----------------------	--



Hydraulic Controls

Power distribution	via control valves with integrated safety valves, simultaneous and independent actuation of chassis, swing drive and equipment
Servo circuit	
Equipment and swing	with hydraulic pilot control and proportional joystick levers
Chassis	electro-proportional via foot pedal
Additional functions	via switch or electro-proportional foot pedals
Proportional control	proportionally acting transmitters on the joysticks for additional hydraulic functions



Hydraulic System

Hydraulic pump	Liebherr axial piston variable displacement pump
for equipment and travel drive	
Max. flow	250 l/min.
Max. pressure	350 bar
Hydraulic pump regulation and control	Liebherr-Synchron-Comfort-system (LSC) with electronic engine speed sensing regulation, pressure and flow compensation, torque controlled swing drive priority
Hydraulic tank	130 l
Hydraulic system	300 l
Hydraulic oil filter	1 main return filter with integrated partial micro filtration (5 µm)
MODE selection	adjustment of engine and hydraulic performance via a mode pre-selector to match application, e.g. for especially economical and environmentally friendly operation or for maximum material handling and heavy-duty jobs
S (Sensitive)	mode for precision work and lifting through very sensitive movements
E (Eco)	mode for especially economical and environmentally friendly operation
P (Power)	mode for high performance with low fuel consumption
P+ (Power-Plus)	mode for highest performance and for very heavy duty applications, suitable for continuous operation
Engine speed and performance setting	stepless alignment of engine output and hydraulic power via engine speed
Option	Tool Control: 20 pre-adjustable pump flows and pressures for add-on attachments



Swing Drive

Drive	Liebherr axial piston motor with integrated brake valve and torque control
Swing ring	Liebherr, sealed race ball bearing swing ring, internal teeth
Swing speed	0 – 10.0 RPM stepless
Swing torque	54 kNm
Holding brake	wet multi-disc (spring applied, pressure released)
Option	slewing gear brake Comfort



Operator's Cab

Cab	TOPS safety cab structure (tip-over protection) with individual windscreens or featuring a slide-in subpart under the ceiling, work headlights integrated in the ceiling, a door with a sliding window (can be opened on both sides), large stowing and depositing possibilities, shock-absorbing suspension, sound damping insulating, tinted laminated safety glass, separate shades for the sunroof window and windscreen
Operator's seat Comfort	air cushioned operator's seat with 3D-adjustable armrests, headrest, lap belt, seat heater, adjustable seat cushion inclination and length, lockable horizontal suspension, automatic weight adjustment, adjustable suspension stiffness, pneumatic lumbar vertebrae support and passive seat climatisation with active coal
Operator's seat Premium (Option)	in addition to operator's seat comfort: active electronic weight adjustment (automatic re-adjustment), pneumatic low frequency suspension and active seat climatisation with active coal and ventilator
Arm consoles	joysticks with control consoles and swivel seat, folding left control console
Operation and displays	large high-resolution operating unit, self-explanatory, colour display with touchscreen, video-compatible, numerous settings, control and monitoring options, e.g. air conditioning control, fuel consumption, machine and attachment parameters
Air-conditioning	automatic air-conditioning, recirculated air function, fast de-icing and demisting at the press of a button, air vents can be operated via a menu; recirculated air and fresh air filters can be easily replaced and are accessible from the outside; heating-cooling unit, designed for extreme outside temperatures, sensors for solar radiation, inside and outside temperatures
Refrigerant	R134a
Global warming potential	1,430
Quantity at 25 °C*	1,300 – 1,500 g
CO ₂ equivalent*	1.859 – 2.145 t
Vibration emission**	
Hand/arm vibrations	< 2.5 m/s ²
Whole-body vibrations	< 0.5 m/s ²
Measuring inaccuracy	according with standard EN 12096:1997

* depending on configuration

** for risk assessment according to 2002/44/EC see ISO/TR 25398:2006



Undercarriage

Drive	oversized two speed power shift transmission with additional creeper speed, Liebherr axial piston motor with functional brake valve on both sides
Travel speed	
Joystick steering	0 – 3.5 km/h stepless (creeper speed + transmission stage 1) 0 – 7.0 km/h stepless (transmission stage 1) 0 – 12.0 km/h stepless (creeper speed + transmission stage 2) 0 – 12.0 km/h stepless (transmission stage 2)
Wheel steering (Option)	0 – 3.5 km/h stepless (creeper speed + transmission stage 1) 0 – 7.0 km/h stepless (transmission stage 1) 0 – 13.0 km/h stepless (creeper speed + transmission stage 2) 0 – 20.0 km/h stepless (transmission stage 2)
Driving operation	automotive driving using accelerator pedal, cruise control function: storage of variable accelerator pedal positions
Axles	32 t drive axles; manual or automatic hydraulically controlled front axle oscillation lock
Service brake	two circuit travel brake system with accumulator; wet and backlash-free disc brake
Holding brake	wet multi-disc (spring applied, pressure released)
Stabilization	stabilizing blade + 2 point outriggers; 4 point outriggers



Equipment

Type	high-strength steel plates at highly-stressed points for the toughest requirements. Complex and stable mountings of equipment and cylinders
Hydraulic cylinders	Liebherr cylinders with special sealing and guide system and, depending on cylinder type, shock absorption
Bearings	sealed, low maintenance



Complete Machine

Lubrication	Liebherr central lubrication system for upper-carriage and equipment, automatically
Steps system	safe and durable access system with anti-slip steps; main components hot-galvanised
Noise emission	
ISO 6396	L _{PA} (inside cab) = 70 dB(A) (Stage V)
2000/14/EC	L _{WA} (surround noise) = 100 dB(A) (Stage V)
ISO 6396	L _{PA} (inside cab) = not specified (Stage Tier 4f)
2000/14/EC	L _{WA} (surround noise) = not specified (Stage Tier 4f)

Dimensions

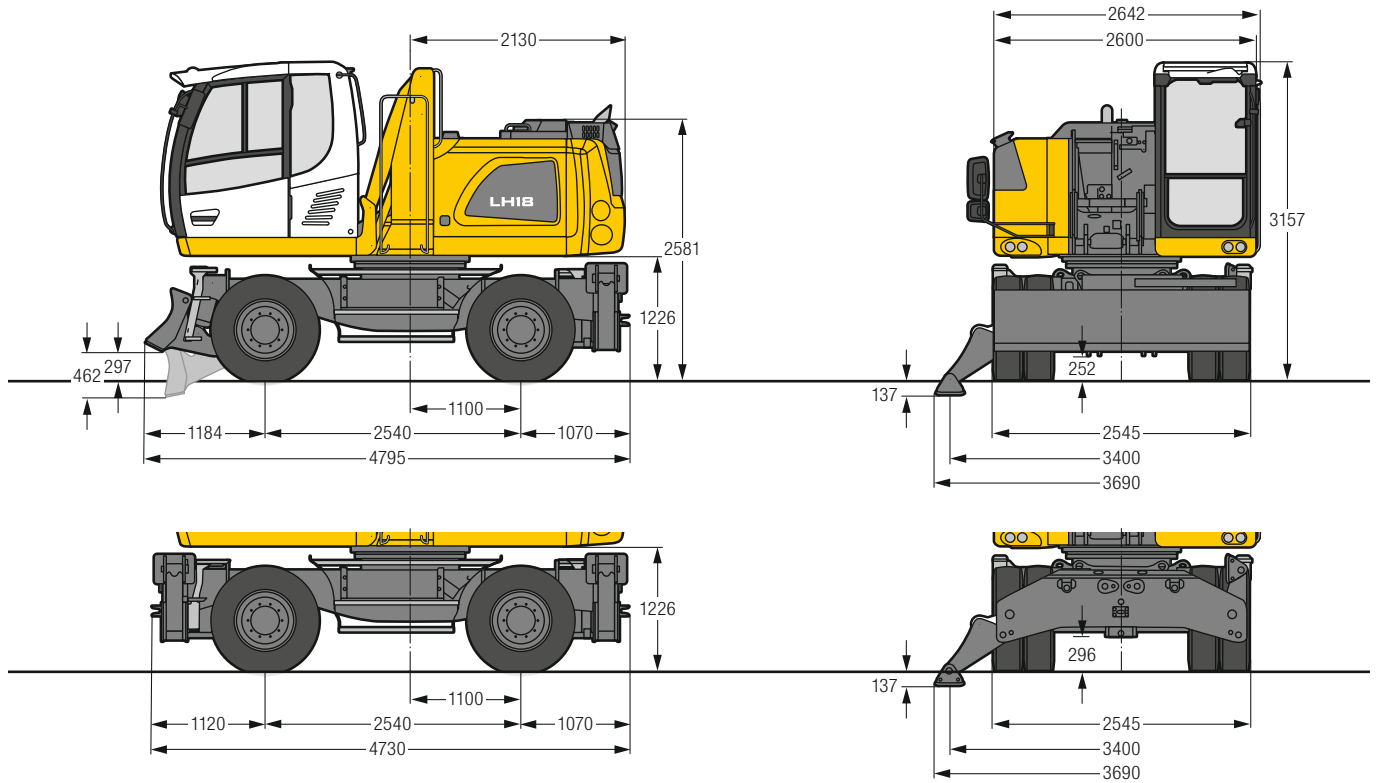

Choice of Cab Elevation

Cab Elevation LHC (Hydraulic Elevation)

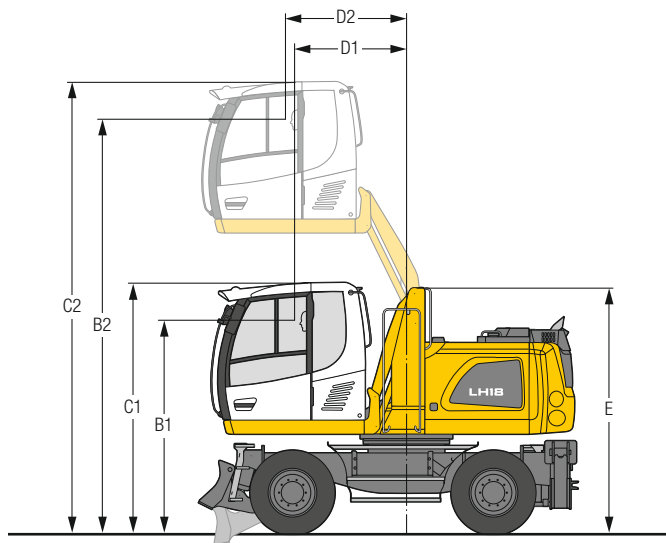

Increase type	LHC 255
B1	2,690 mm
B2	5,230 mm
C1	3,157 mm
C2	5,698 mm
D1	1,420 mm
D2	1,529 mm
E	3,098 mm

The hydraulically adjustable cab allows the driver, that he can choose his field of view freely and at any time within the stroke.

Tyres 10.00-20

Equipment VK8

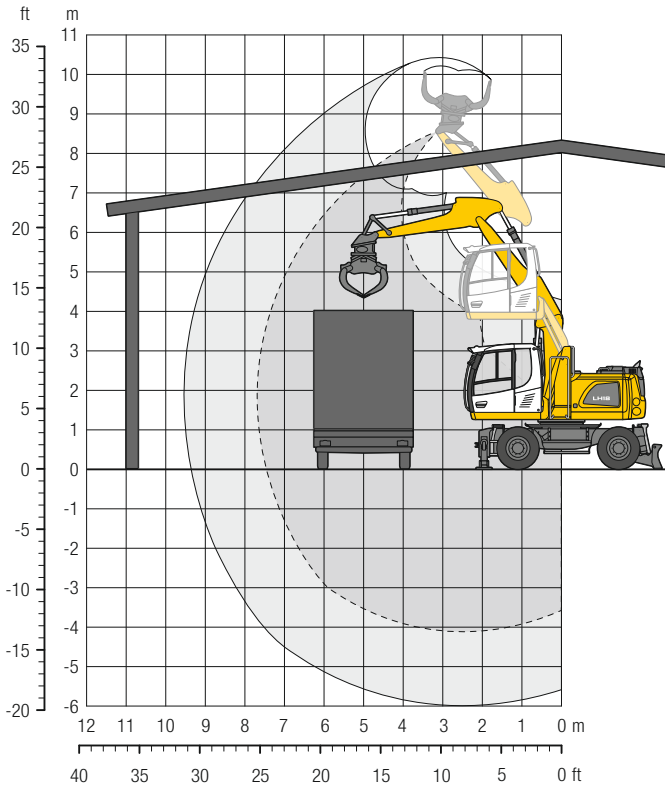

Operating Weight

The operating weight includes the basic machine with stabilizing blade + 2 point outriggers, hydr. cab elevation, 8 solid tyres plus intermediate rings, two-piece boom 4.85 m, stick with tipping kinematics 2.65 m and sorting grab SG 20B/0.40 m³ perforated shells.

Weight 19,200 kg

Dimensions

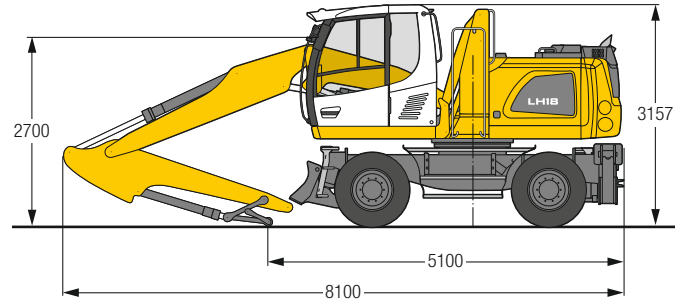

m	Undercarriage	3.0 m		4.5 m		6.0 m		7.5 m		m		
7.5	Stabilizers raised			3.2*	3.2*					2.3*	2.3*	4.9
	Blade + 2 pt. outriggers down			3.2*	3.2*					2.3*	2.3*	
	4 pt. outriggers down			3.2*	3.2*					2.3*	2.3*	
6.0	Stabilizers raised			3.9*	3.9*	2.7	2.9*			2.0*	2.0*	6.3
	Blade + 2 pt. outriggers down			3.9*	3.9*	2.9*	2.9*			2.0*	2.0*	
	4 pt. outriggers down			3.9*	3.9*	2.9*	2.9*			2.0*	2.0*	
4.5	Stabilizers raised			4.3	4.6*	2.8	4.1*			1.9*	1.9*	7.2
	Blade + 2 pt. outriggers down			4.6*	4.6*	4.1*	4.1*			1.9*	1.9*	
	4 pt. outriggers down			4.6*	4.6*	4.1*	4.1*			1.9*	1.9*	
3.0	Stabilizers raised	7.4	9.0*	4.2	5.8*	2.8	4.2	1.8	2.3*	1.8	1.9*	7.6
	Blade + 2 pt. outriggers down	9.0*	9.0*	5.8*	5.8*	4.3	4.5*	2.3*	2.3*	1.9*	1.9*	
	4 pt. outriggers down	9.0*	9.0*	5.8*	5.8*	4.5*	4.5*	2.3*	2.3*	1.9*	1.9*	
1.5	Stabilizers raised	7.2	9.6*	4.1	6.2	2.7	4.2	1.8	2.9	1.7	2.0*	7.7
	Blade + 2 pt. outriggers down	9.6*	9.6*	6.4	6.5*	4.3	4.8*	3.0*	3.0*	2.0*	2.0*	
	4 pt. outriggers down	9.6*	9.6*	6.5*	6.5*	4.8*	4.8*	3.0*	3.0*	2.0*	2.0*	
0	Stabilizers raised	7.2	10.5*	4.0	6.2	2.6	4.1			1.8	2.2*	7.5
	Blade + 2 pt. outriggers down	10.5*	10.5*	6.4	6.7*	4.2	4.8*			2.2*	2.2*	
	4 pt. outriggers down	10.5*	10.5*	6.7*	6.7*	4.8*	4.8*			2.2*	2.2*	
-1.5	Stabilizers raised	6.9	10.8*	3.8	6.3	2.4	3.9			1.9	2.7*	6.9
	Blade + 2 pt. outriggers down	10.8*	10.8*	6.6	6.8*	4.1	4.7*			2.7*	2.7*	
	4 pt. outriggers down	10.8*	10.8*	6.8*	6.8*	4.7*	4.7*			2.7*	2.7*	
-3.0	Stabilizers raised	6.7	10.7*	3.6	6.0*					2.4	2.8*	5.9
	Blade + 2 pt. outriggers down	10.7*	10.7*	6.0*	6.0*					2.8*	2.8*	
	4 pt. outriggers down	10.7*	10.7*	6.0*	6.0*					2.8*	2.8*	

Height Can be slewed through 360° In longitudinal position of undercarriage Max. reach * Limited by hydr. capacity

The lift capacities on the stick end without attachment are stated in metric tons (t) and are valid on a firm, level supporting surface with blocked oscillating axle. These capacities can be slewed through 360° with the undercarriage in the transverse position. Capacities in the longitudinal position of the undercarriage (+/- 15°) are specified over the steering axle with the stabilizers raised and over the rigid axle with the stabilizers down. The values apply with the optimum positioning of the two-piece boom. Indicated loads based on the ISO 10567 standard and do not exceed 75% of tipping or 87% of hydraulic capacity. The lift capacity of the unit is limited by its stability, the lifting capability of the hydraulic elements, or the maximum permissible lifting capacity of the load hook.

In accordance with the harmonised European Standard EN 474-5, hydraulic excavators used for lifting operations must be equipped with pipe fracture safety valves, an overload warning device, a load hook and a lift capacity chart.

Equipment MK7

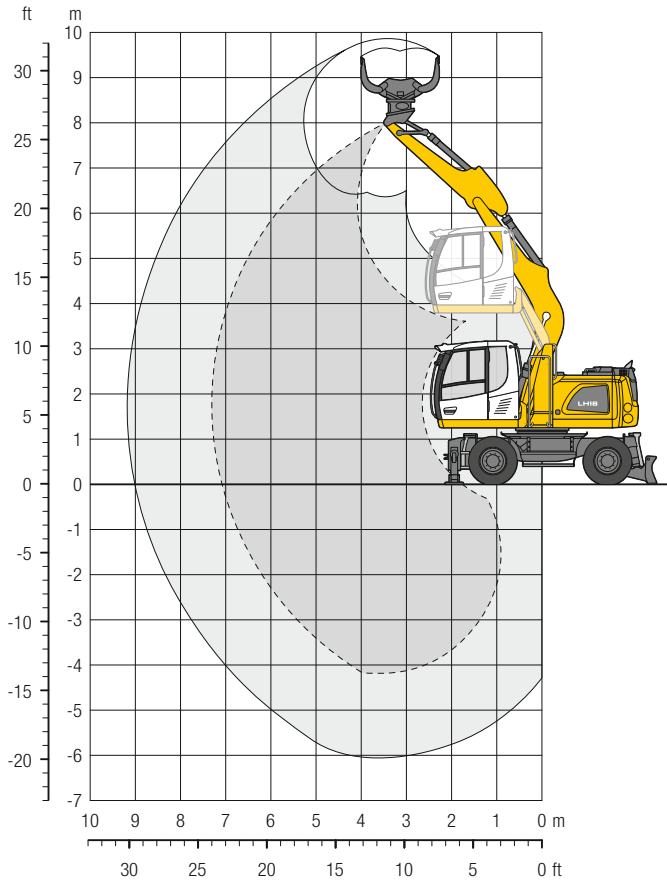

Operating Weight

The operating weight includes the basic machine with stabilizing blade + 2 point outriggers, hydr. cab elevation, 8 solid tyres plus intermediate rings, mono boom 4.60 m, stick with tipping kinematics 2.65 m and sorting grab SG 20B/0.40 m³ perforated shells.

Weight 18,800 kg

Dimensions

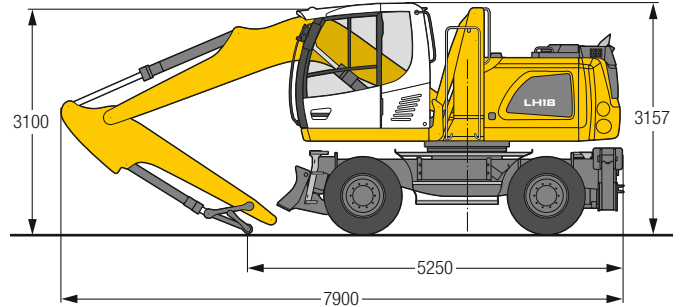

Notice

4 point outriggers with mono boom 4.60 m are only approved for applications with a maximum material density of 0.5 t/m³.

m	Undercarriage	3.0 m		4.5 m		6.0 m		7.5 m		m		
7.5	Stabilizers raised									2.3*	2.3*	4.3
	Blade + 2 pt. outriggers down									2.3*	2.3*	
	4 pt. outriggers down									2.3*	2.3*	
6.0	Stabilizers raised			3.4*	3.4*					1.9*	1.9*	5.9
	Blade + 2 pt. outriggers down			3.4*	3.4*					1.9*	1.9*	
	4 pt. outriggers down			3.4*	3.4*					1.9*	1.9*	
4.5	Stabilizers raised			3.9*	3.9*	2.7	3.6*			1.9*	1.9*	6.8
	Blade + 2 pt. outriggers down			3.9*	3.9*	3.6*	3.6*			1.9*	1.9*	
	4 pt. outriggers down			3.9*	3.9*	3.6*	3.6*			1.9*	1.9*	
3.0	Stabilizers raised	7.2*	7.2*	4.0	4.9*	2.6	4.1*			1.9*	1.9*	7.2
	Blade + 2 pt. outriggers down	7.2*	7.2*	4.9*	4.9*	4.1*	4.1*			1.9*	1.9*	
	4 pt. outriggers down	7.2*	7.2*	4.9*	4.9*	4.1*	4.1*			1.9*	1.9*	
1.5	Stabilizers raised	6.3*	6.3*	3.7	6.0*	2.5	4.0			1.9	2.1*	7.3
	Blade + 2 pt. outriggers down	6.3*	6.3*	6.0*	6.0*	4.2	4.5*			2.1*	2.1*	
	4 pt. outriggers down	6.3*	6.3*	6.0*	6.0*	4.5*	4.5*			2.1*	2.1*	
0	Stabilizers raised	6.2	6.4*	3.5	5.9	2.4	3.9			1.9	2.4*	7.1
	Blade + 2 pt. outriggers down	6.4*	6.4*	6.2	6.6*	4.1	4.8*			2.4*	2.4*	
	4 pt. outriggers down	6.4*	6.4*	6.6*	6.6*	4.8*	4.8*			2.4*	2.4*	
-1.5	Stabilizers raised	6.2	9.2*	3.4	5.8	2.4	3.8			2.1	3.0*	6.5
	Blade + 2 pt. outriggers down	9.2*	9.2*	6.1	6.5*	4.0	4.7*			3.0*	3.0*	
	4 pt. outriggers down	9.2*	9.2*	6.5*	6.5*	4.7*	4.7*			3.0*	3.0*	
-3.0	Stabilizers raised	6.3	8.1*	3.5	5.5*					2.7	4.2*	5.4
	Blade + 2 pt. outriggers down	8.1*	8.1*	5.5*	5.5*					4.2*	4.2*	
	4 pt. outriggers down	8.1*	8.1*	5.5*	5.5*					4.2*	4.2*	

Height Can be slewed through 360° In longitudinal position of undercarriage Max. reach * Limited by hydr. capacity

The lift capacities on the stick end without attachment are stated in metric tons (t) and are valid on a firm, level supporting surface with blocked oscillating axle. These capacities can be slewed through 360° with the undercarriage in the transverse position. Capacities in the longitudinal position of the undercarriage (+/- 15°) are specified over the steering axle with the stabilizers raised and over the rigid axle with the stabilizers down. Indicated loads based on the ISO 10567 standard and do not exceed 75% of tipping or 87% of hydraulic capacity. The lift capacity of the unit is limited by its stability, the lifting capability of the hydraulic elements, or the maximum permissible lifting capacity of the load hook.

In accordance with the harmonised European Standard EN 474-5, hydraulic excavators used for lifting operations must be equipped with pipe fracture safety valves, an overload warning device, a load hook and a lift capacity chart.

Equipment VG8

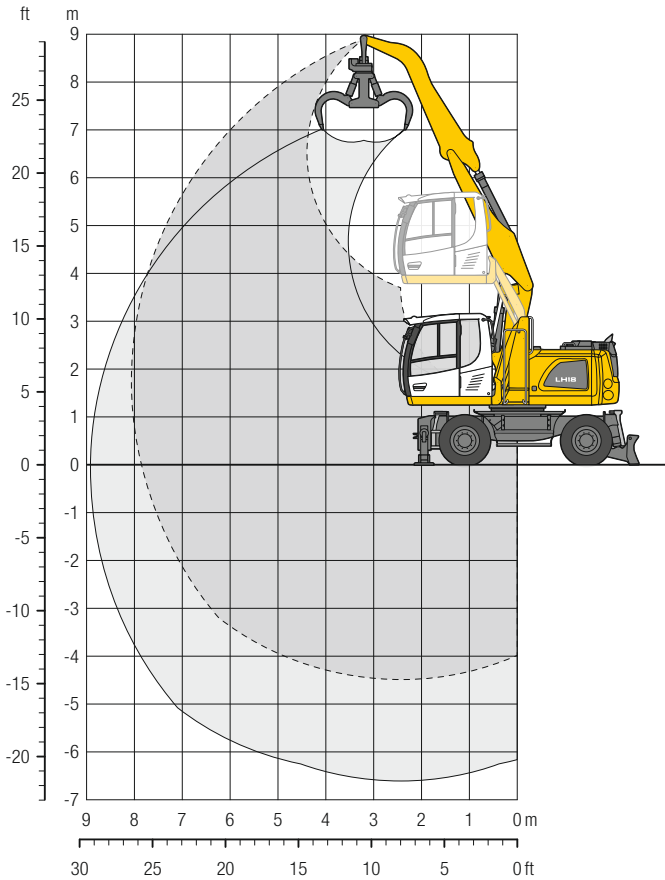

Operating Weight

The operating weight includes the basic machine with stabilizing blade + 2 point outriggers, hydr. cab elevation, 8 solid tyres plus intermediate rings, two-piece boom 4.85 m, angled stick 3.00 m and multi-tine grab GM 55B/0.40 m³ semi-closed tines.

Weight 19,000 kg

Dimensions

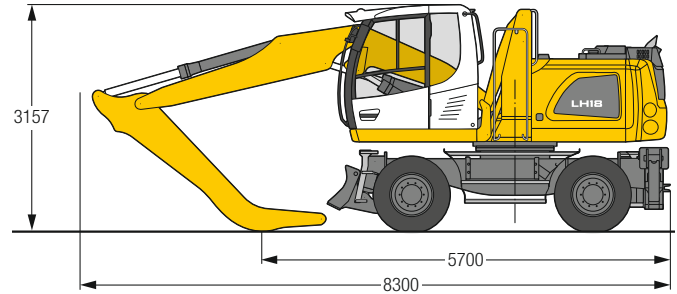

m	Undercarriage	3.0 m		4.5 m		6.0 m		7.5 m		m		
7.5	Stabilizers raised			3.6*	3.6*					2.3*	2.3*	5.5
	Blade + 2 pt. outriggers down			3.6*	3.6*					2.3*	2.3*	
	4 pt. outriggers down			3.6*	3.6*					2.3*	2.3*	
6.0	Stabilizers raised			3.6*	3.6*	3.0	3.4*			2.0*	2.0*	6.8
	Blade + 2 pt. outriggers down			3.6*	3.6*	3.4*	3.4*			2.0*	2.0*	
	4 pt. outriggers down			3.6*	3.6*	3.4*	3.4*			2.0*	2.0*	
4.5	Stabilizers raised			3.9*	3.9*	3.0	3.9*	2.0	2.2*	1.9*	1.9*	7.6
	Blade + 2 pt. outriggers down			3.9*	3.9*	3.9*	3.9*	2.2*	2.2*	1.9*	1.9*	
	4 pt. outriggers down			3.9*	3.9*	3.9*	3.9*	2.2*	2.2*	1.9*	1.9*	
3.0	Stabilizers raised	7.6	8.5*	4.3	5.7*	3.0	4.3	2.0	3.1	1.8	1.9*	8.0
	Blade + 2 pt. outriggers down	8.5*	8.5*	5.7*	5.7*	4.5	4.5*	3.3	3.3*	1.9*	1.9*	
	4 pt. outriggers down	8.5*	8.5*	5.7*	5.7*	4.5*	4.5*	3.3*	3.3*	1.9*	1.9*	
1.5	Stabilizers raised	7.4	9.7*	4.3	6.4	2.9	4.3	2.0	3.1	1.8	2.0*	8.1
	Blade + 2 pt. outriggers down	9.7*	9.7*	6.6*	6.6*	4.5	4.9*	3.2	3.9*	2.0*	2.0*	
	4 pt. outriggers down	9.7*	9.7*	6.6*	6.6*	4.9*	4.9*	3.9*	3.9*	2.0*	2.0*	
0	Stabilizers raised	7.4	10.5*	4.2	6.4	2.8	4.3	1.9	3.0	1.8	2.2*	7.9
	Blade + 2 pt. outriggers down	10.5*	10.5*	6.6	6.9*	4.5	5.0*	3.2	3.8*	2.2*	2.2*	
	4 pt. outriggers down	10.5*	10.5*	6.9*	6.9*	5.0*	5.0*	3.8*	3.8*	2.2*	2.2*	
-1.5	Stabilizers raised	7.1	11.0*	4.0	6.5	2.6	4.1			2.0	2.5*	7.3
	Blade + 2 pt. outriggers down	11.0*	11.0*	6.7	6.9*	4.3	5.1*			2.5*	2.5*	
	4 pt. outriggers down	11.0*	11.0*	6.9*	6.9*	5.0*	5.0*			2.5*	2.5*	
-3.0	Stabilizers raised	7.0	11.3*	3.8	6.3	2.5	3.8*			2.3	2.9*	6.4
	Blade + 2 pt. outriggers down	11.3*	11.3*	6.6	6.8*	3.8*	3.8*			2.9*	2.9*	
	4 pt. outriggers down	11.3*	11.3*	6.7*	6.7*	3.8*	3.8*			2.9*	2.9*	

Height Can be slewed through 360° In longitudinal position of undercarriage Max. reach * Limited by hydr. capacity

The lift capacities on the stick end without attachment are stated in metric tons (t) and are valid on a firm, level supporting surface with blocked oscillating axle. These capacities can be slewed through 360° with the undercarriage in the transverse position. Capacities in the longitudinal position of the undercarriage (+/- 15°) are specified over the steering axle with the stabilizers raised and over the rigid axle with the stabilizers down. The values apply with the optimum positioning of the two-piece boom. Indicated loads based on the ISO 10567 standard and do not exceed 75% of tipping or 87% of hydraulic capacity. The lift capacity of the unit is limited by its stability, the lifting capability of the hydraulic elements, or the maximum permissible lifting capacity of the load hook.

In accordance with the harmonised European Standard EN 474-5, hydraulic excavators used for lifting operations must be equipped with pipe fracture safety valves, an overload warning device, a load hook and a lift capacity chart.

Equipment MG8

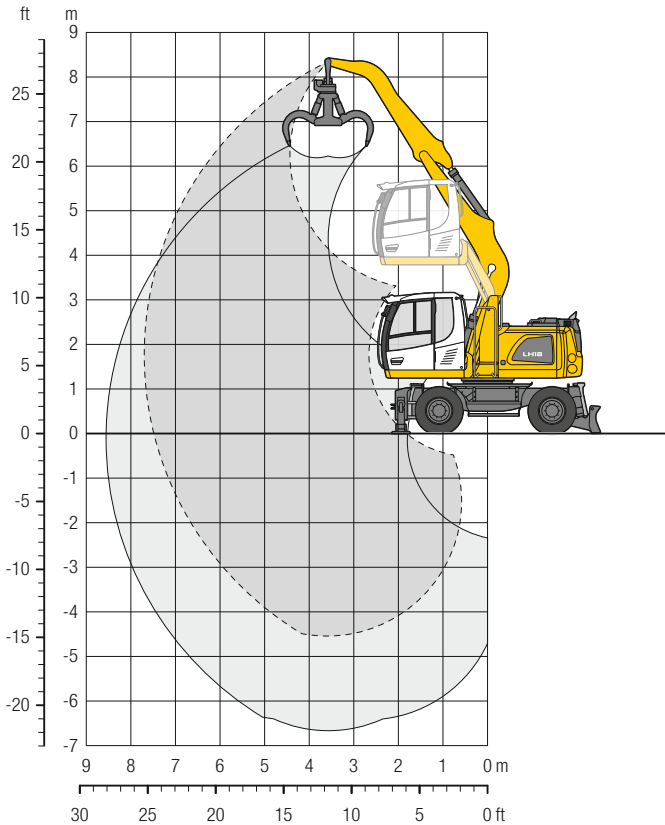

Operating Weight

The operating weight includes the basic machine with stabilizing blade + 2 point outriggers, hydr. cab elevation, 8 solid tyres plus intermediate rings, mono boom 4.60 m, angled stick 3.00 m and multi-tine grab GM 55B/0.40 m³ semi-closed tines.

Weight 18,700 kg

Dimensions

Equipment over digging axle for transport

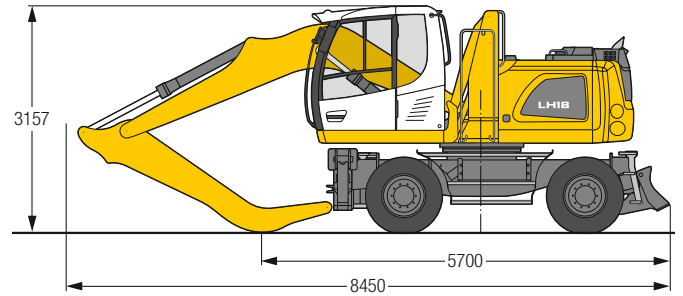

Notice

4 point outriggers with mono boom 4.60 m are only approved for applications with a maximum material density of 0.5 t/m³.

m	Undercarriage	3.0 m		4.5 m		6.0 m		7.5 m		m		
7.5	Stabilizers raised			3.0*	3.0*					2.3*	2.3*	4.9
	Blade + 2 pt. outriggers down			3.0*	3.0*					2.3*	2.3*	
	4 pt. outriggers down			3.0*	3.0*					2.3*	2.3*	
6.0	Stabilizers raised			3.2*	3.2*	2.8*	2.8*			2.0*	2.0*	6.4
	Blade + 2 pt. outriggers down			3.2*	3.2*	2.8*	2.8*			2.0*	2.0*	
	4 pt. outriggers down			3.2*	3.2*	2.8*	2.8*			2.0*	2.0*	
4.5	Stabilizers raised			3.7*	3.7*	2.9	3.6*			1.9*	1.9*	7.2
	Blade + 2 pt. outriggers down			3.7*	3.7*	3.6*	3.6*			1.9*	1.9*	
	4 pt. outriggers down			3.7*	3.7*	3.6*	3.6*			1.9*	1.9*	
3.0	Stabilizers raised	6.5*	6.5*	4.2	4.8*	2.8	4.1*	2.0	2.3*	1.9*	1.9*	7.6
	Blade + 2 pt. outriggers down	6.5*	6.5*	4.8*	4.8*	4.1*	4.1*	2.3*	2.3*	1.9*	1.9*	
	4 pt. outriggers down	6.5*	6.5*	4.8*	4.8*	4.1*	4.1*	2.3*	2.3*	1.9*	1.9*	
1.5	Stabilizers raised	6.8	8.0*	3.9	6.0*	2.7	4.2	2.0	2.8*	1.9	2.0*	7.7
	Blade + 2 pt. outriggers down	8.0*	8.0*	6.0*	6.0*	4.4	4.6*	2.8*	2.8*	2.0*	2.0*	
	4 pt. outriggers down	8.0*	8.0*	6.0*	6.0*	4.6*	4.6*	2.8*	2.8*	2.0*	2.0*	
0	Stabilizers raised	6.4*	6.4*	3.7	6.1	2.6	4.1			1.9	2.3*	7.5
	Blade + 2 pt. outriggers down	6.4*	6.4*	6.4	6.8*	4.3	5.0*			2.3*	2.3*	
	4 pt. outriggers down	6.4*	6.4*	6.8*	6.8*	5.0*	5.0*			2.3*	2.3*	
-1.5	Stabilizers raised	6.4	8.6*	3.6	6.0	2.5	4.0			2.1	2.8*	6.9
	Blade + 2 pt. outriggers down	8.6*	8.6*	6.3	6.8*	4.2	5.0*			2.8*	2.8*	
	4 pt. outriggers down	8.6*	8.6*	6.8*	6.8*	5.0*	5.0*			2.8*	2.8*	
-3.0	Stabilizers raised	6.5	9.0*	3.7	6.0					2.6	3.9*	5.9
	Blade + 2 pt. outriggers down	9.0*	9.0*	6.1*	6.1*					3.9*	3.9*	
	4 pt. outriggers down	9.0*	9.0*	6.1*	6.1*					3.9*	3.9*	
-4.5	Stabilizers raised									4.1*	4.1*	4.1
	Blade + 2 pt. outriggers down									4.1*	4.1*	
	4 pt. outriggers down									4.1*	4.1*	

Height Can be slewed through 360° In longitudinal position of undercarriage Max. reach * Limited by hydr. capacity

The lift capacities on the stick end without attachment are stated in metric tons (t) and are valid on a firm, level supporting surface with blocked oscillating axle. These capacities can be slewed through 360° with the undercarriage in the transverse position. Capacities in the longitudinal position of the undercarriage (+/- 15°) are specified over the steering axle with the stabilizers raised and over the rigid axle with the stabilizers down. Indicated loads based on the ISO 10567 standard and do not exceed 75% of tipping or 87% of hydraulic capacity. The lift capacity of the unit is limited by its stability, the lifting capability of the hydraulic elements, or the maximum permissible lifting capacity of the load hook.

In accordance with the harmonised European Standard EN 474-5, hydraulic excavators used for lifting operations must be equipped with pipe fracture safety valves, an overload warning device, a load hook and a lift capacity chart.

Machine Stabilities Sorting Grabs

LH 18 M – Max. Material Weight in t/m³

Grab	Shell type	Capacity m ³	Direct mounting with mounting plate				Mounting with SWA 48			
			Blade + 2 pt. outriggers down		4 pt. outriggers down		Blade + 2 pt. outriggers down		4 pt. outriggers down	
			VK8	MK7	VK8	MK7	VK8	MK7	VK8	MK7
SG 20B	perforated	0.40	2.0	2.2	2.0	0.5	1.3	1.5	1.3	0.5
SG 20B	perforated	0.50	1.5	1.7	1.5	0.5	0.9	1.1	0.9	0.5
SG 20B	perforated	0.60	1.1	1.3	1.1	0.5	0.7	0.8	0.7	0.5
SG 20B	perforated	0.70	0.9	1.0	0.9	0.5	0.5	0.7	0.5	0.5
SG 20B	closed	0.40	1.9	2.2	1.9	0.5	1.2	1.5	1.2	0.5
SG 20B	closed	0.50	1.4	1.6	1.4	0.5	0.9	1.1	0.9	0.5
SG 20B	closed	0.60	1.1	1.3	1.1	0.5	0.7	0.8	0.7	0.5
SG 20B	closed	0.70	0.9	1.0	0.9	0.5	0.5	0.6	0.5	0.5

Notice

4 point outriggers with mono boom 4.60 m are only approved for applications with a maximum material density of 0,5 t/m³.

Equipment

Undercarriage

4 point outriggers, rear + front outriggers	+
Front stabilizer blade, rear outriggers	+
Individual control outriggers	•
Shuttle axle lock, automatic	•
Outrigger monitoring system	+
Tyres, variants	+
Protection for travel drive	•
Protection for piston rods, outriggers	+
Two storage compartments	•

Upper-carriage

Upper-carriage right side light, 1 piece, LED	•
Upper-carriage rear light, 2 pieces, LED	+
Tank refilling pump fuel	+
Main battery switch for electrical system	•
Amber beacon, at upper-carriage, LED double flash	+
Protection for headlights	+
Protection for rear lights	+
Tool equipment, extended	+

Hydraulic System

Electronic pump regulation	•
Liebherr hydraulic oil from -20 °C to +40 °C	•
Liebherr hydraulic oil, biologically degradable	+
Magnetic rod in hydraulic tank	•
Bypass filter	+
Preheating hydraulic oil	+

Engine

Fuel anti-theft device	+
Air pre-filter with dust discharge	+
Automatic engine shut-down (time adjustable)	+
Preheating fuel	+
Preheating coolant *	+
Preheating engine oil *	+

Cooling System

Reversible fan drive	+
Protective grid (close-mesh) in front of cooler intake, extendible	•



Operator's Cab

Stabilizer, control lever, left console	+
Stabilizer, proportional control on left joystick	•
Cab lights front, halogen	+
Cab lights front, halogen (under rain cover)	•
Cab lights front, LED	+
Cab lights front, LED (under rain cover)	+
Armrest adjustable	•
Slewing gear brake Comfort, button on the left or right joystick	+
Operator's seat Comfort	•
Operator's seat Premium	+
Driving alarm (acoustic signal is emitted during travel, can be switched ON/OFF)	+
Fire extinguisher	+
Footrest	+
Horn, button on left joystick	•
Joystick steering (max. 12 km/h)	•
Cab elevation, hydraulic (LHC)	•
Cab elevation, hydraulic with tilt function (LHC)	+
Automatic air conditioning	•
Wheel steering (slim version)	+
LiDAT, vehicle fleet management	•
Proportional control	•
Radio Comfort, control via display with handsfree set	+
Preparation for radio installation	•
Back-up alarm (acoustic signal is emitted traveling backward, can not be switched off)	+
Amber beacon, on cabin, LED double flash	+
Windows made from impact-resistant laminated safety glass	+
Windscreen wiper, roof	+
Windshield wiper, entire windscreen	•
FOPS top guard	+
FGPS front guard, tiltable	+
Sun visor	+
Left control console, folding	•



Equipment

Boom lights, 2 pieces, halogen	•
Boom lights, 2 pieces, LED	+
Stick lights, 2 pieces, halogen	•
Stick lights, 2 pieces, LED	+
Height limitation and stick shutoff, electronically	+
Stick camera (with separate monitor), bottom side, with protection	+
Load holding valve tipping cylinder	+
Liebherr quick coupler, hydraulic	+
Pipe fracture safety valves hoist cylinders	•
Pipe fracture safety valves stick cylinders	•
Quick coupling system LIKUFIX	+
Protection for piston rod, tipping cylinder	+
Overload warning device	+
Two-piece boom, HD version	+



Complete Machine

Lubrication	
Lubrication undercarriage, manually – decentralised (grease points)	•
Lubrication undercarriage, manually – centralised (one grease point)	+
Central lubrication system for uppercarriage and equipment, automatically	•
Special coating	
Special coating, variants	+
Monitoring	
Rear view monitoring with camera	•
Side view monitoring with camera	•

• = Standard, + = Option

* = country-dependent

Options and / or special equipments, supplied by vendors other than Liebherr, are only to be installed with the knowledge and approval of Liebherr in order to retain warranty.

Attachments

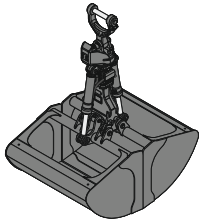

Grab for Loose Material

Shells for loose material with cutting edge (without teeth)

Grab model GMZ 26

Width of shells	mm	1,250	1,500
Capacity	m ³	1.50	1.80
Weight	kg	1,170	1,255

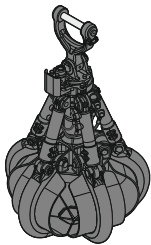

Multi-Tine Grab

open

semi-closed

closed

Grab model GM 55B (5 tines)

Capacity	m ³	0.40	0.40	0.40*
Weight	kg	995	1,120	1,375

* heart-shaped

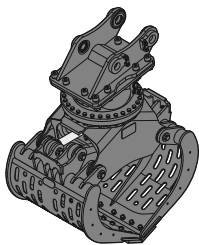

Sorting Grab

perforated

closed

perforated

closed

perforated

closed

perforated

closed

Grab model SG 20B

Width of shells	mm	800	800	1,000	1,000	1,200	1,200	1,400	1,400
Capacity	m ³	0.40	0.40	0.50	0.50	0.60	0.60	0.70	0.70
Max. closing force	kN	40	40	40	40	40	40	40	40
Weight incl. adapter plate SWA	kg	950	965	995	1,010	1,040	1,050	1,085	1,095

The Liebherr Group of Companies



Wide Product Range

The Liebherr Group is one of the largest construction equipment manufacturers in the world. Liebherr's high-value products and services enjoy a high reputation in many other fields. The wide range includes domestic appliances, aerospace and transportation systems, machine tools and maritime cranes.

Exceptional Customer Benefit

Every product line provides a complete range of models in many different versions. With both their technical excellence and acknowledged quality, Liebherr products offer a maximum of customer benefits in practical applications.

State-of-the-art Technology

To provide consistent, top quality products, Liebherr attaches great importance to each product area, its components and core technologies. Important modules and components are developed and manufactured in-house, for instance the entire drive and control technology for construction equipment.

Worldwide and Independent

Hans Liebherr founded the Liebherr family company in 1949. Since then, the family business has steadily grown to a group of more than 140 companies with nearly 48,000 employees located on all continents. The corporate headquarters of the Group is Liebherr-International AG in Bulle, Switzerland. The Liebherr family is the sole owner of the company.

www.liebherr.com