

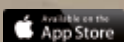

**KOMPTECH**  
TECHNOLOGY FOR A BETTER ENVIRONMENT

MOBILE STAR SCREENS

# MULTISTAR



EDITION WITH AUGMENTED REALITY CONTENT



Download the „KompTech LookBeyond!“ app. Scan marked and numbered projects with the „LookBeyond! eye“ to see additional information.



APPLICATION

# SCREENING WITH STARS



1

green efficiency

## HIGHLIGHTS

- » Separation into 2 or 3 fractions on one machine, in one pass
- » High throughput and precise selectivity with the CLEANSTAR system
- » High flexibility with particle size changes in just seconds
- » Ease of operation and simple servicing
- » Extremely efficient with all components electric powered

Screening is a fundamental treatment stage in the processing of waste, recyclables and biomass. Star screen technology is increasingly used for the job, and in most cases the screener is a Multistar. The reason is simple - one machine and one pass are sufficient to divide the material into 2 or 3 fractions. Thanks to the patented cleaning system, throughput and selectivity are high, even with moist material.

To change the particle size, the operator just presses a button – the machine does the rest. The electrical drive gives quiet, efficient and economical operation. With a host of options, there is a configuration that is ideal for virtually any application and system size. Magnet separation, wind sifting and separation of the rolling fraction make star screens multi-functional workhorses.



2

## Biomass: Green waste, rootstocks, forestry residue, fresh compost

Using star screen technology, high-quality fuel can be extracted from shredded, woody biomass in just one screening run. The rotating stars disentangle the material and knock off any dirt or mud. What is output as fine or oversized particles is decided from the operator console. Variations in the material are evened out, and a high quality usable fraction is assured.



3

## Compost: Green compost, bio-compost, sludge compost

Screening is always in season with Multistar star screens. Throughput and selectivity are high, even with fluctuations in moisture content and states of decomposition. Options such as wind sifting, Fe separation and separation of the rolling fraction ensure a quality compost product that is free of contaminants.



4

## Wood: Treated/untreated waste wood, wood chips, bark

Star screens give impressively high throughput, and can produce all particle sizes commonly required in the market. Fines and overlengths are reliably separated out, and Fe separation and wind sifting can be added if required.



5

## Waste: Commercial waste, MSW, residual waste

Fractions with high calorific value are separated from shredded waste fractions by the disc separator/star screen combination (MS L3 Flowerdisc). High throughput, low wear, and thus low maintenance overhead are the hallmarks of this flexible mobile solution.





# INSIDE THE MACHINE

The core of the star screens consists of one or two screen decks, depending on the model. The rotating shafts of the coarse screen deck move the material horizontally. Everything that cannot fall through the defined gap between the stars is separated off as coarse material. Material falling through the screen moves on the fine screen deck fitted with smaller stars, and is separated into fine and medium fractions in the same way. The screening flow from coarse to fine delivers high quality output in a short screen length, and keeps larger contraries out of the fine fraction.

Particle size can be controlled by varying the rotation speed of the star shafts. Using frequency converters on the operator console, the particle size can be changed within seconds within the range determined by the star geometry. All functions are monitored by a central control unit which reports on the current operational status.

- 01 Hopper with scraper conveyor
- 02 Metering drum
- 03 Coarse screen deck
- 04 Fine screen deck
- 05 Diesel generator

## SCREENING

Particle size		
Coarse 	Medium 	Fine 
Screen sections		
0/60...90 mm 0/90...120 mm 0/120...150 mm	0/30...60 mm	0/10...25 mm 0/15...30 mm with spacer bushings 0/8...20 mm with attachment rings
Type of star		
8-finger star Ø=340 mm (width: 55, 84, 110 mm)	8-finger star Ø=340 mm	12-finger star Ø=166 mm
		





**Komptech LookBeyond!**

Scan and see additional information about the Multistar.

6



**SCREEN DECKS -  
COARSE BEFORE FINE**

- » Coarse before fine screening delivers high-quality output in compact machine dimensions
- » Fast, easy reconfiguration of screen decks thanks to modular design



**STAR WEAR PROTECTION**

- » Geometrically optimised, highly elastic stars with cleaning elements
- » Low wear costs through individually replaceable stars and CLEANSTAR cleaning elements



**ECONOMICAL HYBRID DRIVE**

- » Electric drive of all components, from grid power or a diesel generator
- » Lower fuel, wear, and maintenance costs than with diesel-hydraulic drive



EFFICIENT



7

# MULTISTAR ONE

## HIGHLIGHTS

- » Semi-mobile 2-fraction star screen with return conveyor on a hook lift frame
- » 6.5 m<sup>2</sup> screen area for throughput of up to 200 m<sup>3</sup>/h
- » Large hopper volume up to 2.5 m<sup>3</sup> with scraper conveyor and feed roller
- » Hybrid drive: Energy can be sourced from the grid or supplied from the shredder by hydraulic generator

The new Multistar One makes waste wood and biomass processing highly efficient. An upstream Crambo handles the shredding, and the One then takes care of separating out a defined useful fraction while returning overlengths to the shredder. With a feed hopper for precise material transfer to the generously dimensioned screen deck, a discharge conveyor with 4 m cone height and a return conveyor that can pivot through 220°, the One is ready to deliver up to 200 m<sup>3</sup>/h throughput.

The machine is built on a hook-lift frame, making it compact. The conveyors are designed for flexible positioning, while the low-wear screen deck and electric power ensure top economy. Along with two maintenance doors, tough truck-grade tarp material protects components from dirt while saving weight and affording easy access.

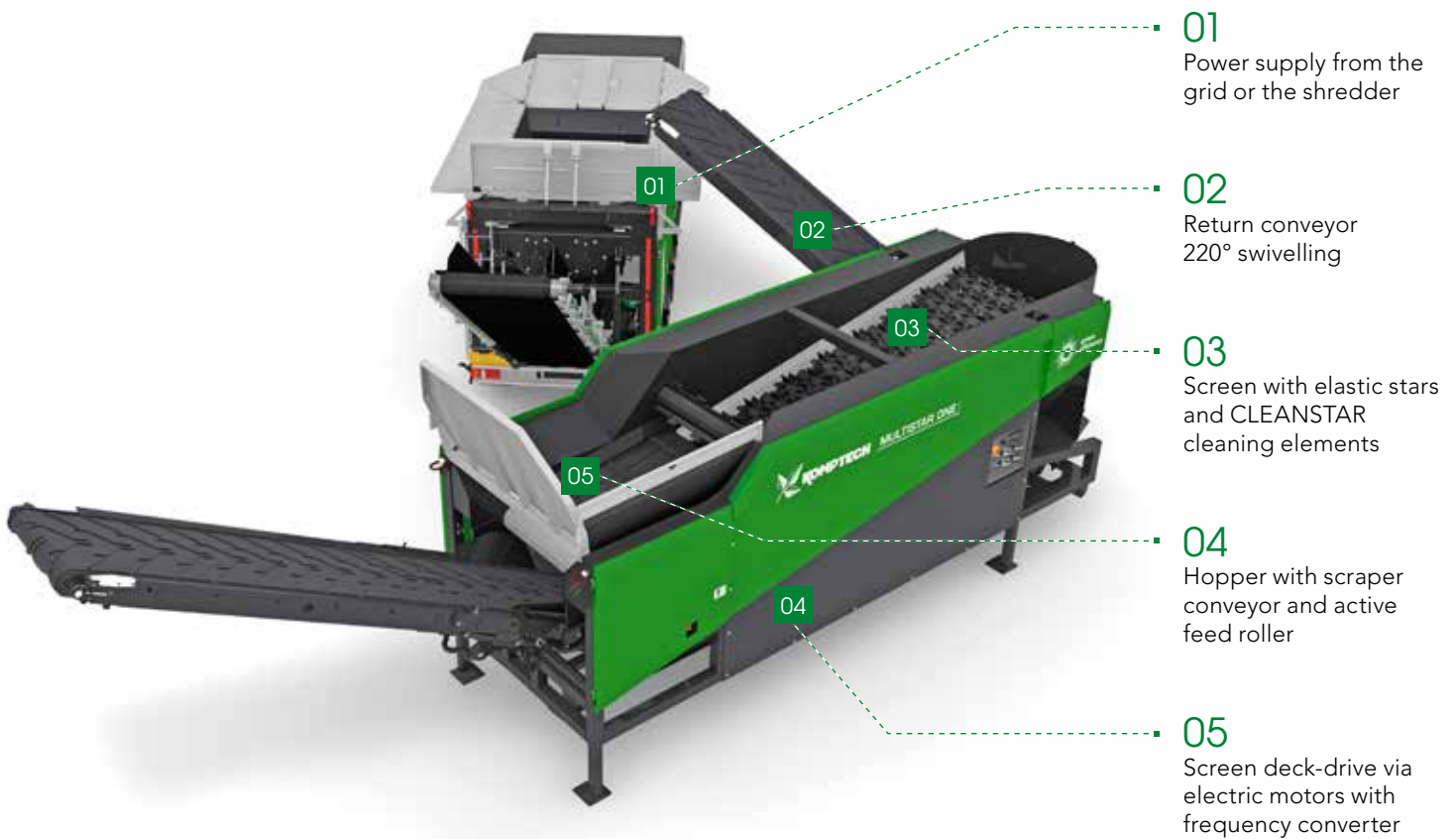

**01**  
Power supply from the grid or the shredder

**02**  
Return conveyor  
220° swivelling

**03**  
Screen with elastic stars  
and CLEANSTAR  
cleaning elements

**04**  
Hopper with scraper  
conveyor and active  
feed roller

**05**  
Screen deck-drive via  
electric motors with  
frequency converter



#### CONTROLLED TRANSFER

The shredder discharge conveyor feeds material to the 2.5 cubic metre capacity feed hopper of the One. There, a scraper conveyor and an optional feed roller ensure controlled material transfer to the screen deck.



#### SURE MATERIAL RETURN

The screen overflow falls through a chute to the return conveyor. The conveyor swivels through 220° for high setup flexibility. With a cone height up to 4 metres, material return to any Komptech shredder is problem-free.



#### FLEXIBLE ENERGY SUPPLY

The current for the electric motors can come either directly from the grid or from a combination of additional hydraulic pump on the shredder and hydraulic generator on the Multistar One.



ENTRY LEVEL



8

# MULTISTAR S3

## HIGHLIGHTS

- » Semi-mobile 3-fraction star screen on a hook lift frame
- » Throughput up to 100 m<sup>3</sup>/h with 2.1 / 3.9 m<sup>2</sup> screen area (coarse screen/fine screen)
- » Large hopper volume up to 3.5 m<sup>3</sup> with low loading height
- » Excellent maintenance access through service doors and easily removable flexible cladding

The Multistar S3 is the entry-level member of Komptech's professional star screen line. Designed expressly for the needs of lower to moderate volume users, the S3 combines low cost with a level of performance previously only available in the high-capacity L and XL class. Built on a hook lift module, it has small dimensions while still offering the requisite mobility for service providers or multi-site use.

Like the higher capacity models, the applications range from compost to green cuttings to bark, chips and shredded waste wood. Similarly, almost all the options of the larger machines are available - wind-sifting of the medium fraction, screen deck variations, switch from 3 to 2 fractions, hopper extensions and much more. High efficiency at low emissions - the S3 naturally meets Komptech's green efficiency® criteria.



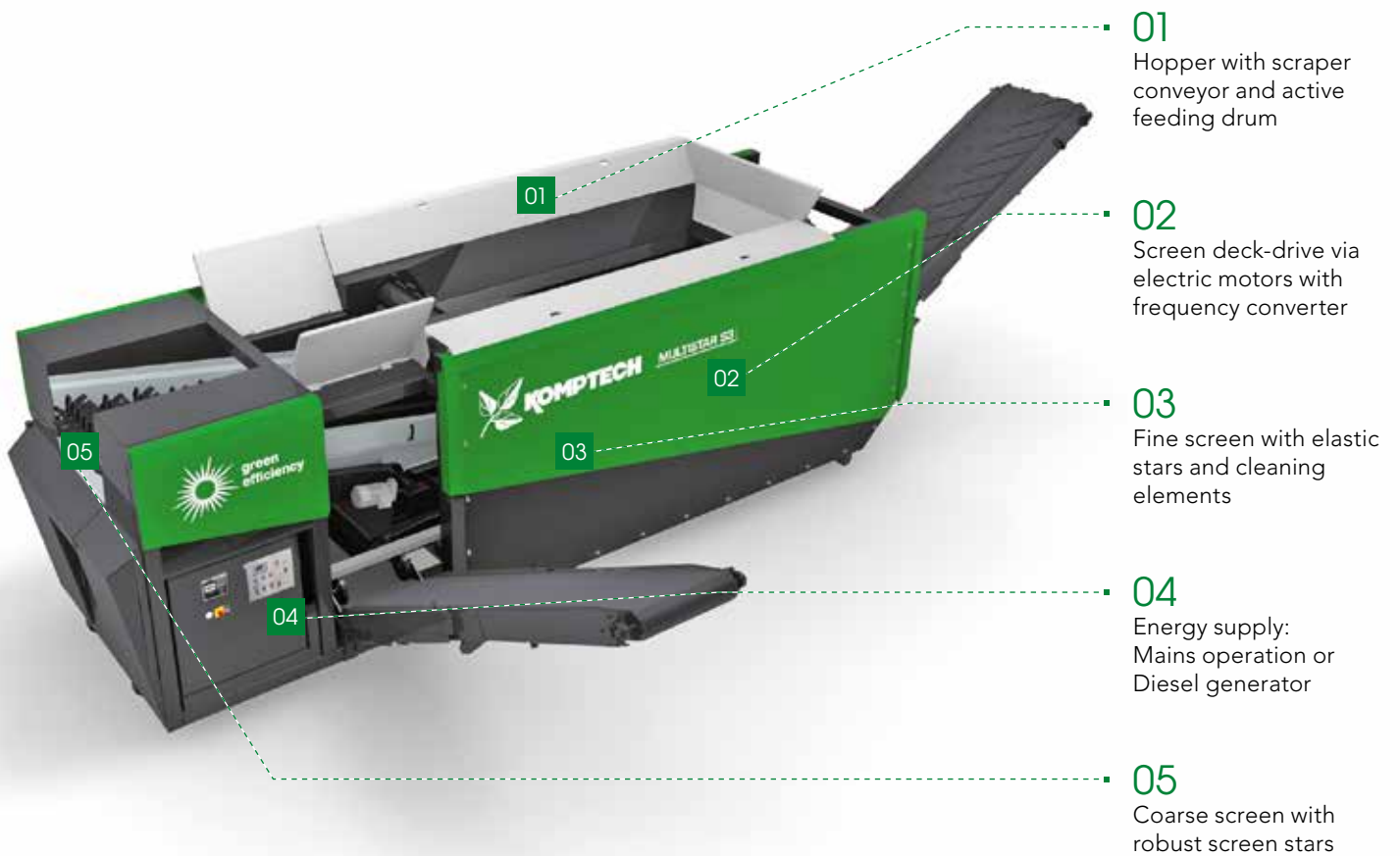

**01**  
Hopper with scraper conveyor and active feeding drum

**02**  
Screen deck-drive via electric motors with frequency converter

**03**  
Fine screen with elastic stars and cleaning elements

**04**  
Energy supply: Mains operation or Diesel generator

**05**  
Coarse screen with robust screen stars



#### THE PERFECT START

A large hopper with up to 3.5 m<sup>3</sup> volume permits continuous loading. The 2.1 m<sup>2</sup> coarse and 3.9 m<sup>2</sup> fine screen decks are matched to it. The discharge conveyor height provides enough buffer capacity for smooth front loader use.



#### A DIFFERENT KIND OF CLADDING

Sheet metal panels with large access doors protect the drive components. Elsewhere, tough truck-grade tarp material protects components from dirt while saving weight. Rolling up the tarp sidewalls affords free access to all other components.



#### SEMI-MOBILE WITH HOOKLIFT

The substructure of the Multistar S3 is a standard hooklift frame. The machine can be transported easily by a 3 or 4-axle truck rated for 7 metre containers.



MULTITALENT



9

# MULTISTAR L3

## HIGHLIGHTS

- » Powerful 3-fraction star screen mounted on central-axle-trailer or semi-trailer
- » Throughput up to 250 m<sup>3</sup>/h with 3.8 / 7.3 m<sup>2</sup> screen area (coarse screen/fine screen)
- » Perfect access to all maintenance positions
- » Multi-functional with numerous options: windsifter, magnet separator etc.

The Multistar L3 is a further improvement of its line of Multistar star screens. High throughput across a wide range of applications, combined with the patented cleaning system for an outstanding degree of separation even with wet materials, make it the most capable machine in its class. And then there's its impressive energy efficiency: All machine components are electrically driven. The power can come from the grid for the lowest cost, or from the on-board generator where grid power isn't available.

Innovative features boost operating flexibility and simplify maintenance. Thus, cover panels don't just protect the components inside, they also serve as access doors for full access to all maintenance points. Other highlights include a cassette configuration of the screen decks for rapid changes, adding flexibility. The screen drive components are tougher, the fines discharge system has been redesigned, and the control setup is even more intuitive.



**01**  
Hopper with scraper conveyor and active metering drum

**02**  
Screen deck-drive via electric motors with frequency converter

**03**  
Fine screen with elastic stars and cleaning elements

**04**  
Energy supply: Diesel generator or mains operation

**05**  
Coarse screen with robust screen stars



### EXTREMELY EFFICIENT

High throughput plus low operating costs equals the highest operating efficiency. The hopper, feed system, and design and dimensions of the screen decks combine to form a compact unit with virtually unbeatable throughput. Effective wear protection of all parts in contact with material and an efficient diesel-electric drive system ensure the lowest operating costs.



### FROM FINE TO COARSE

Particle size can be controlled by varying the rotation speed of the star shafts. In just seconds the particle size can be changed within the range provided by the star size, using the touchscreen graphic control panel. The different star dimensions and arrangements cover screening sections from 8-150 mm.



### MAINTENANCE MADE EASY

On the L3, cover panels don't just protect the components inside, they also serve as access doors for full access to all maintenance points. For maintenance to the fine screen deck the whole hopper unit can be lifted away.



HIGHEST PERFORMANCE



10

# MULTISTAR XL3 / XXL2

## HIGHLIGHTS

- » High-performance machines for large operations
- » Huge hopper and extremely wide discharge belts for ease of operation
- » XL3: Throughput up to 300 m<sup>3</sup>/h with 6 / 6.8 m<sup>2</sup> screen area (coarse screen/fine screen)
- » XXL2: Throughput up to 400 m<sup>3</sup>/h with 11 m<sup>2</sup> screen area (2-fraction star screen)

The Multistar XL3 and XXL2 are the top of the line, top-performance star screens from Komptech. They are designed for the heaviest duty with the highest throughput, while retaining the benefits of mobility.

Heavy-duty components for continuous operation, large screen decks with wide discharge belts, and powerful yet very economical electric drive via diesel generator all keep things moving. The result is unbeatably low operating costs at full capacity production.



**01**  
Hopper with scraper conveyor and active metering drum

**02**  
Fine screen with elastic stars and cleaning elements

**03**  
Screen deck-drive via electric motors with frequency converter

**04**  
Coarse screen with robust screen stars

**05**  
Energy supply:  
Diesel generator or mains operation



### BUILT FOR HIGHEST PERFORMANCE

The XL3 and XXL2 are built for highest performance. The 7 m<sup>3</sup> (XL3) or 10 m<sup>3</sup> (XXL2) hopper can be filled from both sides. Extremely wide output conveyors make sure that what goes in, comes out without a hitch.



### SAVING WITH HYBRID TECHNOLOGY

The power for the drives can come either from grid electric power or the optional built-in diesel generator. The use of grid power reduces energy consumption by up to 75% compared with diesel-hydraulic power.



### FULL MOBILITY

The semi-trailer design makes them easy to move from point A to point B. So nothing stands in the way of off-site use. Extend the supports, fold out the conveyors, and you're ready to run. For difficult terrain the XL3 is also available with a tracked chassis.

# MULTISTAR L3

## TECHNICAL SPECIFICATIONS

# MULTISTAR

	MULTISTAR ONE	MULTISTAR S3	MULTISTAR L3	MULTISTAR XL3	MULTISTAR XXL2
<b>Drive</b>					
Diesel generator (kVA):		45 (option)	60/85 (option)	60	60
Power consumption (kW):	up to 25				
<b>Material feeding</b>					
Hopper volume (m³):	2.5	2.5 / 3.5 (option)	~ 7	~ 7	~ 10
Filling length (mm):	2300	3100	3750	3400	4000
Filling height (mm):	2500 / 3000	2500 / 3000	3450	3500	3200
<b>Screen segments</b>					
Coarse screen L x W (mm) / area (m²):	4500 x 1450 / 6,5	2400 x 900 / 2.1	3198 x 1200 / 3.85	5000 x 1200 / 6.0	
Fine screen L x W (mm) / area (m²):		4250 x 900 / 3.9	5852 x 1250 / 7.3	5450 x 1250 / 6.8	7000 x 1600 / 11
<b>Screen section (standard)</b>					
Coarse particle (mm):	> 60.....90   > 90.....120	> 60.....90	> 60.....90	> 20.....50	> 15.....30
Medium particle (mm):		10.....25 / 60.....90	10.....25 / 60.....90	10.....25 / 20.....50	
Fein particle (mm):	0/60.....90   0/90.....120	0 / 10.....25	0 / 10.....25	0 / 10.....25	0 / 15.....30
<b>Material discharge</b>					
Max. discharge height coarse fraction (mm):	4050	2300	2850	3230	3600
Max. discharge height medium fraction (mm):		2900	3500	3500	
Max. discharge height fine fraction (mm):	3950	2300	3500	310	2700
<b>Dimensions</b>					
Transport dimension L x W x H (mm):	8176 x 2466 x 2600	11066 x 5542 x 3000	Trailer 11500 x 2550 x 4000 Semi-trailer 13600 x 2550 x 4000	11900 x 2500 x 4000	13700 x 2500 x 3900
Working dimension L x W x H (mm):	15949 x 2456 x 3900	11066 x 5542 x 3000	Trailer 13600 x 6500 x 4000 Semi-trailer 17200 x 6500 x 4000	16615 x 6500 x 4000	15290 x 4046 x 3900
Weight (t):	~ 9.2	~ 10.0	~ 21.0	~ 22.0	~ 22.0
<b>Throughput (dependent on material)</b>					
Throughput performance (m³/h):	up to 200	up to 100	up to 250	up to 300	up to 400
<b>Options</b>					

Different screen options for coarse and fine screen, magnetic drum, discharge belt for rolling pieces, windsifter, diesel generator towing and chassis options, radio remote control, central lubrication and more

# MULTISTAR ONE

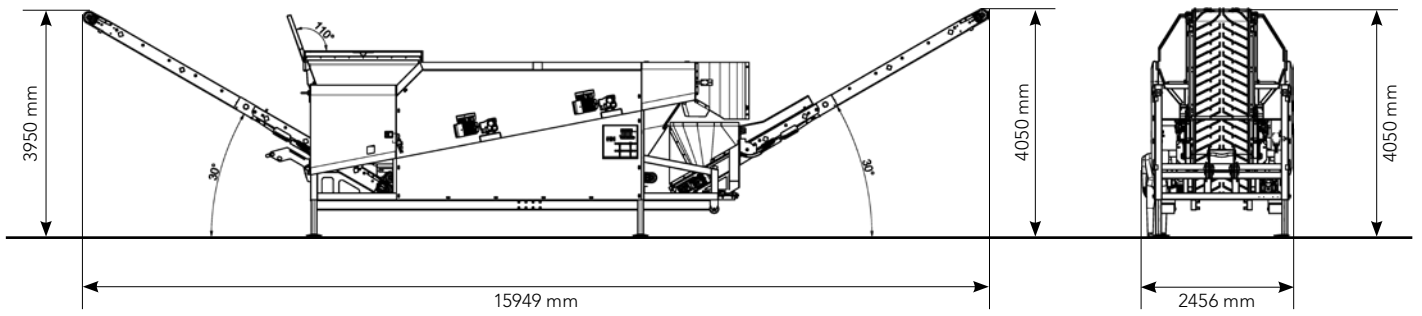

# MULTISTAR S3

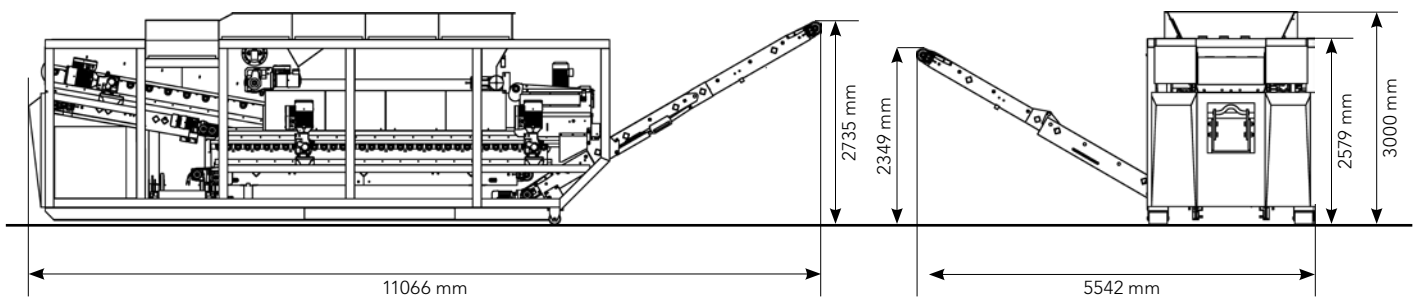

# MULTISTAR L3

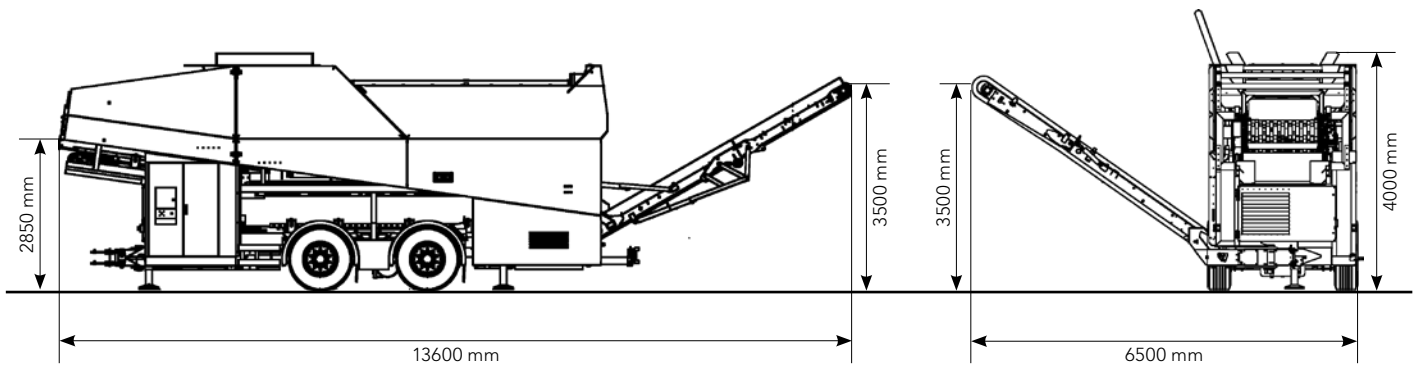

# MULTISTAR XL3

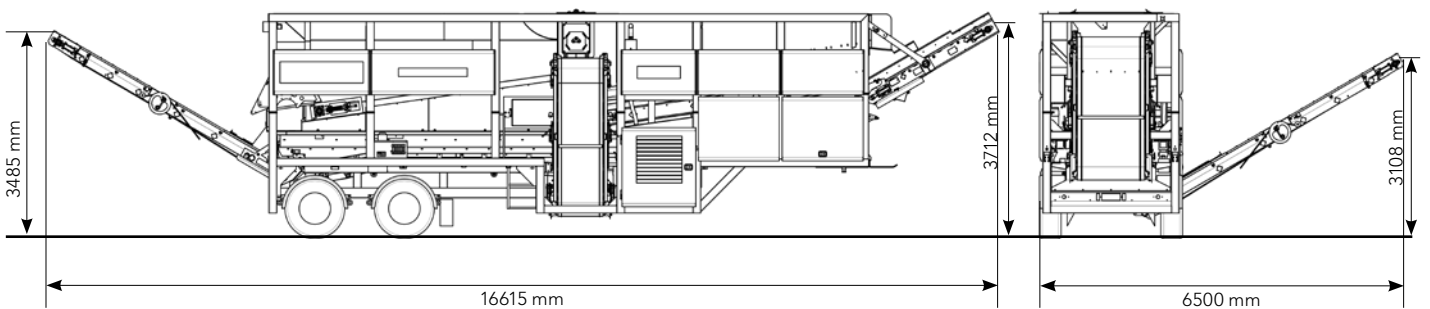

# TECHNOLOGY FOR A BETTER **ENVIRONMENT**



Komptech GmbH  
Kühau 37, A-8130 Frohnleiten, Austria  
[t] +43 3126 505 - 0  
[f] +43 3126 505 - 505  
[e] [info@komptech.com](mailto:info@komptech.com)

[www.komptech.com](http://www.komptech.com)

We reserve the right to make technical changes in the course of ongoing development. E2018