

HURRIFEX  
HURRIKAN  
STONEFEX

---

# SEPARATION

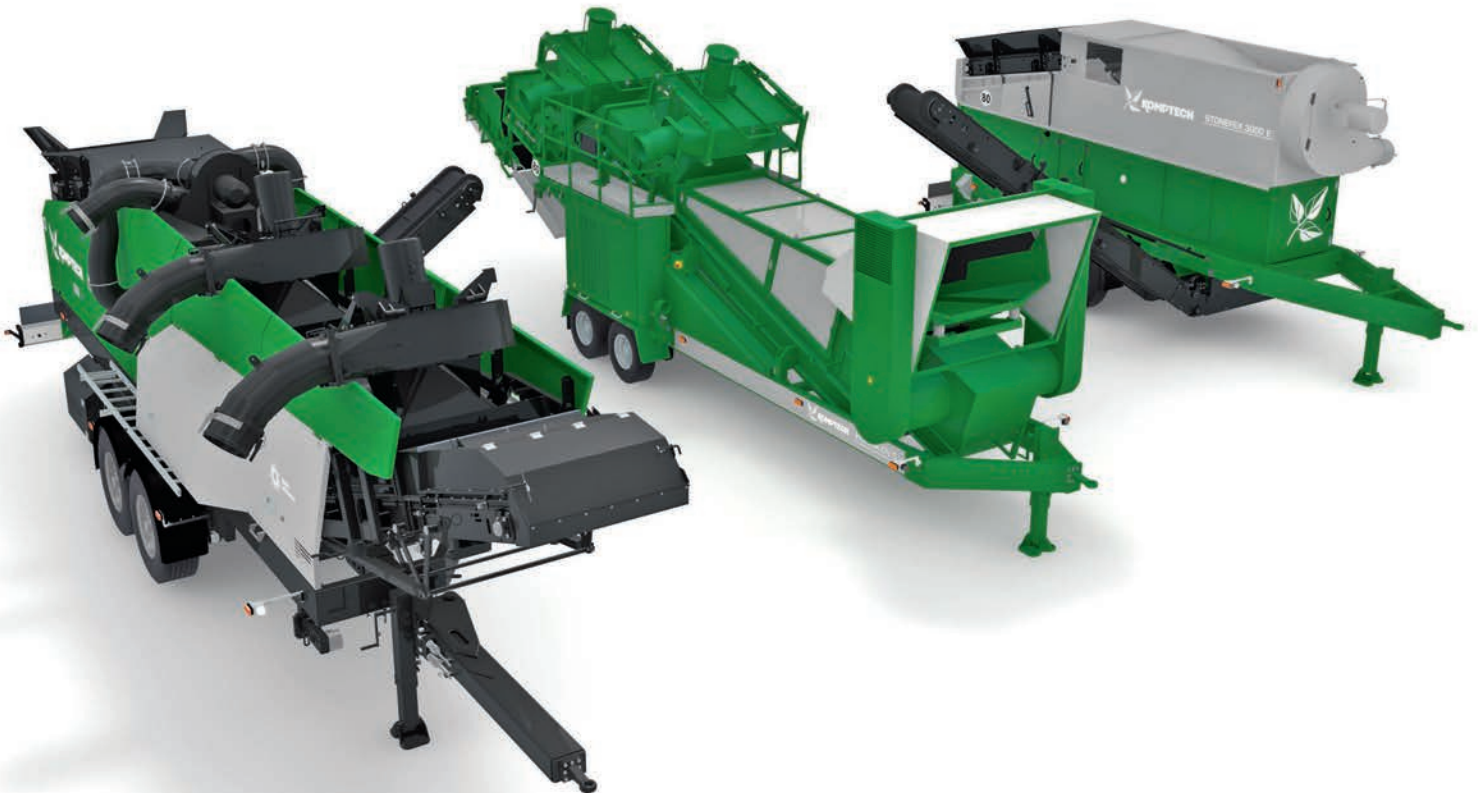



## APPLICATION

# SEPARATION MAKES SENSE

## HIGHLIGHTS

- » Innovative separation technology:  
Hurrikan - wind sifter,  
Stonefex - stone separator,  
Hurrifex - stone and light material separator
- » Complex separation physics inside - simple operation outside
- » Electric drive for efficiency
- » Flexible thanks to generator or mains operation
- » A multitude of applications in recycling

Compost from organic waste and fuel from woody biomass are fundamentals of sustainable resource use, and need to be high in quality without contaminants or harmful materials. In addition to standard screening with with trommel or star screens, other screening steps are increasingly being added to composting, biomass processing and new applications.

Komptech has a wide range of wind sifters, stone separators and combination machines for these purposes - the development of new separation techniques precisely tailored to market requirements has been a focus of our research for many years. The result is pioneering machines that help innovative customers address new business opportunities.



1

### Composting: Screen overflow from organic waste compost, fermentation residues etc.

Screen overflow can be returned to compost as an ideal structure material. But this requires that foreign matter - mostly light materials like plastic film - be removed to as great an extent as possible. The Hurrikan/Hurrikan S wind sifter was developed for just this purpose. It removes light materials from screen overflow with a separation efficiency of over 90 percent. If there are large amounts of light materials as well as stones in the input material, the Hurrifex combination wind sifter and stone separator is the perfect answer.



2

### Biomass processing: Shredded rootstocks, forestry residue, woody biomass, screen overflow etc.

In addition to trunks, which are in demand for fuel as well as for wood, forestry residue, rootstocks and green cuttings can also be used for biofuel. But contamination by stones often makes its use difficult. Stones reduce the quality and price obtainable for biomass fuels. The Stonefex can remove up to 95 percent of heavy items from the input material. If the material is also contaminated with plastic, the Hurrifex is the solution. The benefits for any fuel producer are immediately obvious. Fractions that were previously unsuitable due to their contaminant content can now be used for fuel, and fuel that is almost stone-free naturally commands higher prices.



3

### Special applications: Processing of mixed construction waste, road sweepings, automotive industry shredder waste, etc.

Wherever removal of flat light material, separation between heavy and light pieces or a combination of the two is required, the Hurrifex and its stablemates are the answer. Take mixed construction waste for example - the Hurrifex can vacuum out the plastic film while separating the rest into a heavy mineral fraction and a light woody fraction.



WINDSIFTER

# HURRIKAN HURRIKAN S

## HIGHLIGHTS

---

- » High throughput with up to 95 percent separation precision through optimum adjustability for the material
- » The Hurrikan S has an expanded suction area for higher throughput and separation precision.
- » 80 km/h chassis for high mobility and optional onboard diesel generator for operation at any site
- » The mobile machine can be combined with almost any screen

The Hurrikan wind sifters provide effective removal of plastic film from screen overflow. They work with a patented pressure-suction process that gives the Hurrikan S a separation efficiency of up to 95 percent (up to 90 percent for the Hurrikan). Magnetic and roller separators can further enhance the quality of the recyclable output.

The Hurrikan is offered as a centre axle trailer (tandem axle for the S version). Electric drive of all components ensures top efficiency while offering many control possibilities. An optional generator provides full independence from grid power.

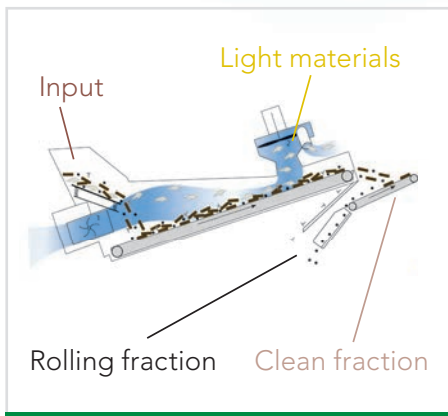
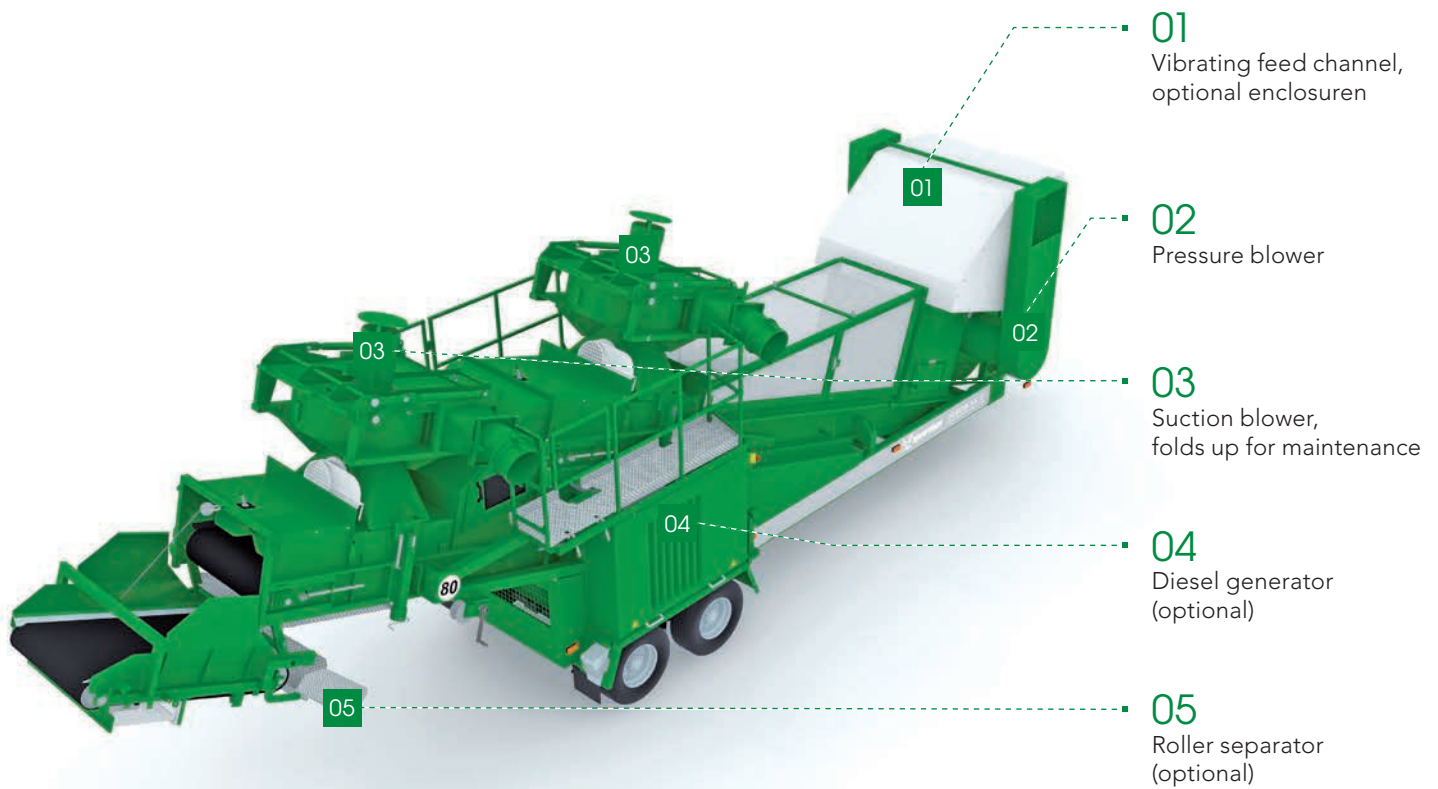

**PATENTED SEPARATING SYSTEM**

The pressure-suction system gives extremely effective removal of light materials from screen overflow. In the first step, the pressure blower separates the material. The light materials settle onto the remaining fraction. In the second step, the light materials are pulled away by a suction blower.



**EXACT CONFIGURATION FOR THE TASK**

The wide feed chute permits a 1200 mm wide screener conveyor and a loading height of 1950 to 2250 mm. Separation can be precisely adjusted for the material by means of blower speed, blower interval and air flaps.



**WITH OPTIONS FOR CLEANING**

The Hurrikan really cleans up with the optional magnetic drum and roller separator - round, heavy objects (mostly rocks) roll down an adjustable-slope conveyor to a chute and away.



STONE SEPARATOR

# STONEFEX

## HIGHLIGHTS

- » Reliable separation of stones and inert material with a separation rate of up to 95 percent.
- » Throughput up to 100 m<sup>3</sup>/h with input sizes from 10...20-150 mm (depending on material and loading)
- » Wide range of applications thanks to adjustable separation parameters
- » Low energy costs thanks to electrical drive of all components

The Stonefex stone separator gets stones and other inert material out of biomass fuels dependably and with high separation efficiency. The input material is the useful biomass fraction from a screen, like woody green cuttings, screen overflow from compost or forestry chips.

A patented system of pressure and suction blower generates exactly the right air flow in the separation chamber to remove stones from the wood. The blowers and discharge conveyors are electrically powered, reducing energy costs and minimizing maintenance effort. The Stonefex is offered in mobile and stationary versions.



**01**  
Adjustable-speed  
feed conveyor

**02**  
Separation chamber with  
pressure blower

**03**  
Corrugated edge belt  
for the stone fraction

**04**  
Suction blower,  
folds up for maintenance

**05**  
Corrugated edge belt  
for use fraction

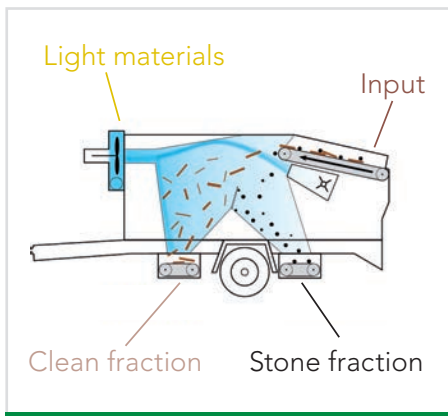

### EFFICIENT SEPARATING SYSTEM

In the expansion chamber, the airflow separates the material into a stone fraction and cleaned usable fraction, which conveyors remove to opposite sides. Fibrous materials are collected in the container downstream of the suction blower. Using the same principle, stones can be cleaned of undesired biomass.

### DEPENDABLE FUNCTION WITH SIMPLE MAINTENANCE

Separation remains dependable even with varying material properties, by adjusting the feed conveyor speed, blower speed and the separating vertex. Large access doors to the separation chamber and engine compartment plus a swivel-mounted suction blower make maintenance simple and convenient.

### MOBILE AND ECONOMICAL

The single-axle trailer configuration makes the machine easy to manoeuvre, and it is approved for 80 kph (50 mph) road speeds, so transportation is no problem. The standard version of the machine uses grid power. As an option it can be fitted with a turbo diesel generator. The hybrid drive design ensures low energy and maintenance costs.



STONE AND LIGHT  
MATERIAL SEPARATOR

HURRIFEX



## HIGHLIGHTS

- » Combination machine:  
Savings in space, materials and transportation logistics compared to two separate machines
- » Very broad range of uses, with simple operation and high availability.
- » Separation efficiency up to 95 with a throughput of 60 m<sup>3</sup>/h (depending on material and loading)

The Hurrifex combines a stone separator and wind sifter in a single machine. This makes it possible to clean compost and biomass fractions of stones and light materials - primarily plastic film - in one pass. Easily adjustable separation parameters give the Hurrifex a wide range of applications, and a separation efficiency of up to 95 percent.

All components are electrically powered, using grid power or the onboard diesel generator. Maintenance doors in the cladding provide full access to all maintenance points. In addition to the stationary version, there are mobile centre axle trailer and semitrailer versions.



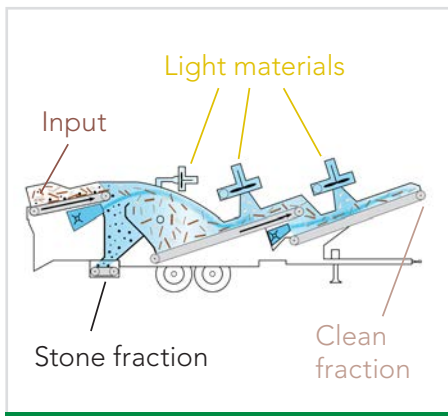
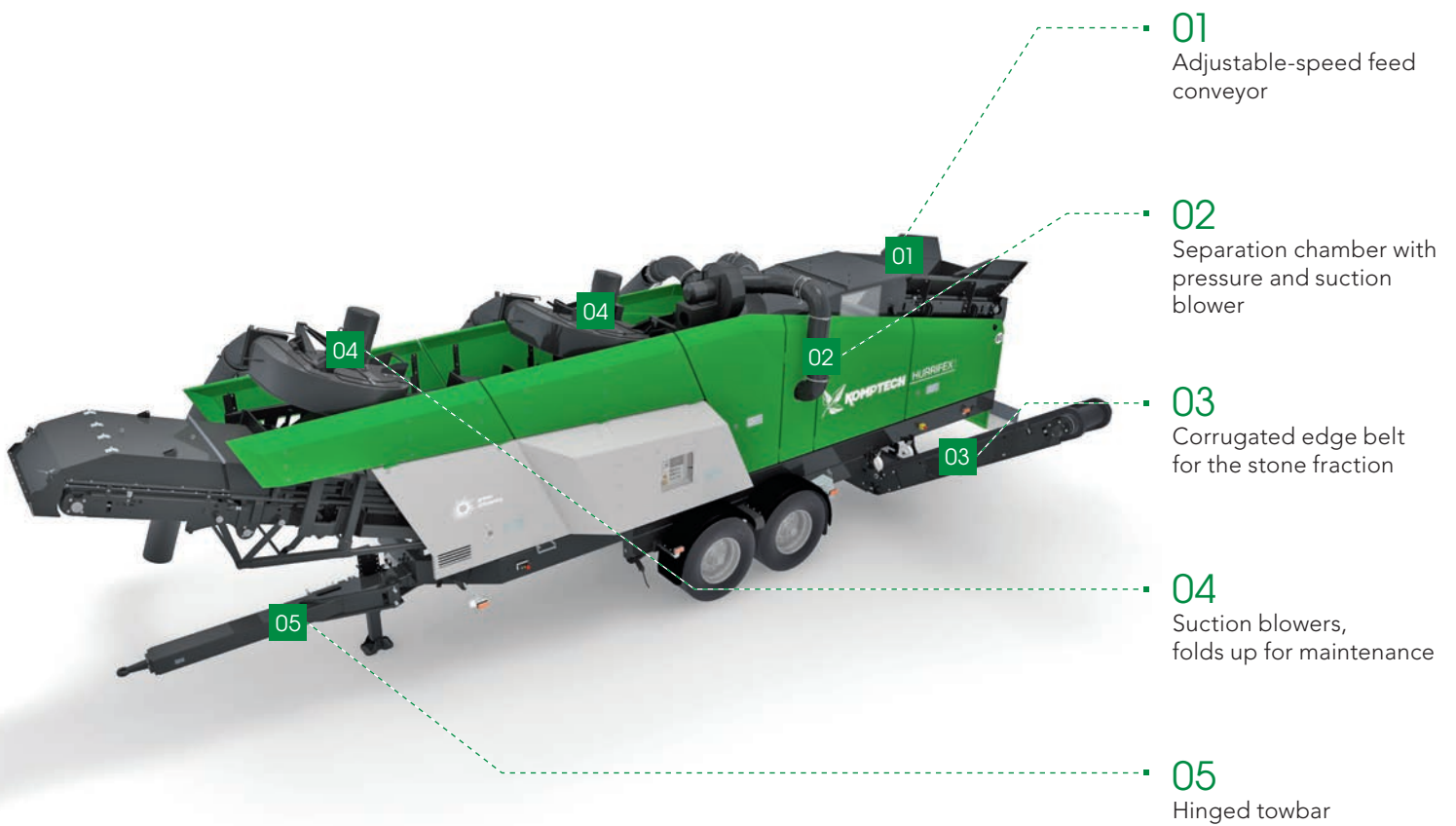

**PHYSICS  
MAKE IT POSSIBLE**

The separation of stones and inert materials is based on differences in density and coefficient of air resistance. Material turning and air flow are critical for efficient suction removal of light materials.

**SAVING ENERGY WITH  
HYBRID TECHNOLOGY**

The power for the drives can come either from grid electric power or an onboard diesel generator. The suction and conveyor blowers are optimized for efficient airflow and draw only a small amount of power.

**CLEAR  
DISCHARGE**

The stone fraction is removed to the side by a corrugated edge belt while light materials are blown into two containers through flexible ducts. The input fraction to be cleaned passes straight through the machine, minimizing the danger of blockage.



## TECHNICAL SPECIFICATIONS

# SEPARATORS

	HURRIKAN	HURRIKAN S	STONEFEX	HURRIFEX
<b>Drive</b>				
Connection power (kW):	28	44	26	48
Diesel generator (kVA):	48	60	30	60
<b>Material feed - feed conveyor</b>				
Loading area width (mm):	1600	1600	1200	1200
Loading height (mm):	Adjustable from 1950 to 2250	Adjustable from 1950 to 2250	3150	2800
<b>Stone fraction discharge</b>				
Design:	-	-	Corrugated edge belt	Corrugated edge belt
Loading height (mm):	-	-	2500 (option 3700)	2500 (option 3700)
<b>Clean fraction discharge</b>				
Design:	Ribbed belt	Ribbed belt	Corrugated edge belt	Ribbed belt
Loading height (mm):	2900	2600	2500 (3700 optional)	3100
<b>Dimensions L x W x H (mm)</b>				
Transport dimensions central-axle-trailer:	8300 x 2550 x 4000	11000 x 2550 x 4000	8300 x 2550 x 4000	12000 x 2550 x 4000
Transport dimensions semitrailer:				13900 x 2550 x 4000
Working dimensions central-axle-trailer	8130/9420* x 3000 x 4100 (*incl. roller separator)	11000/12310* x 3460 x 4000 (*incl. roller separator)	8300 x 7500 x 3700	12400 x 5400 x 4000
Working dimensions semitrailer:				13900 x 5500 x 4100
Total permissible weight (t):	6.5	10.0	10.0	14.0
<b>Throughput (depending on material)</b>				
Throughput (m³/h):	up to 40	up to 60	up to 100	up to 60
<b>Hurrikan options</b>				
Diesel generator, magnet drum, roller separator, frequency-converter for suction blower, special suction channels, enclosure for vibrating feeder and much more				
<b>Stonefex options</b>				
Diesel generator, conveyor extensions, adjustable conveyor speed, electro-hydraulically folding discharge conveyors, central lubrication, frequency converter for suction blower, remote control and much more				
<b>Hurrifex options</b>				
Diesel generator, conveyor extension, adjustable conveyor speed, electro-hydraulically folding discharge conveyor, central lubrication, frequency converter for suction blowers, remote control, enclosure feeding conveyor and much more				

# HURRIKAN

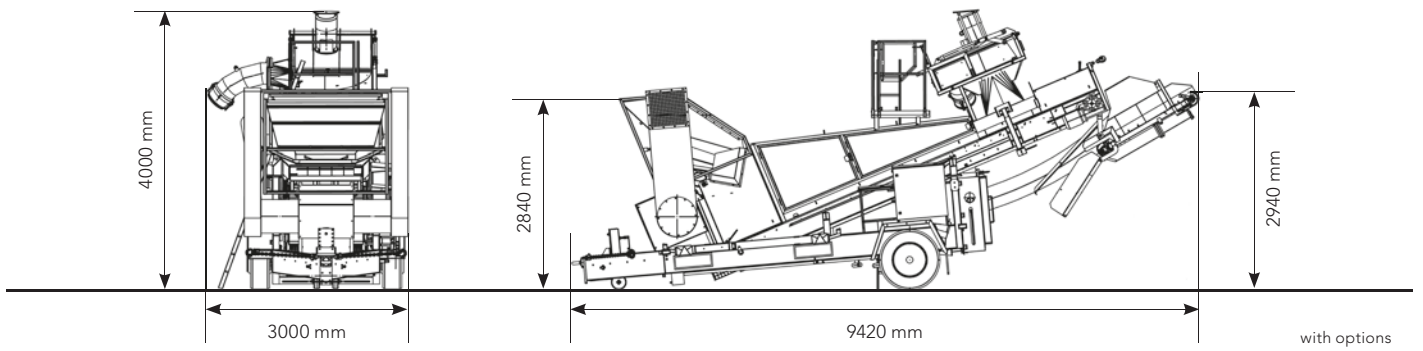

# HURRIKAN S

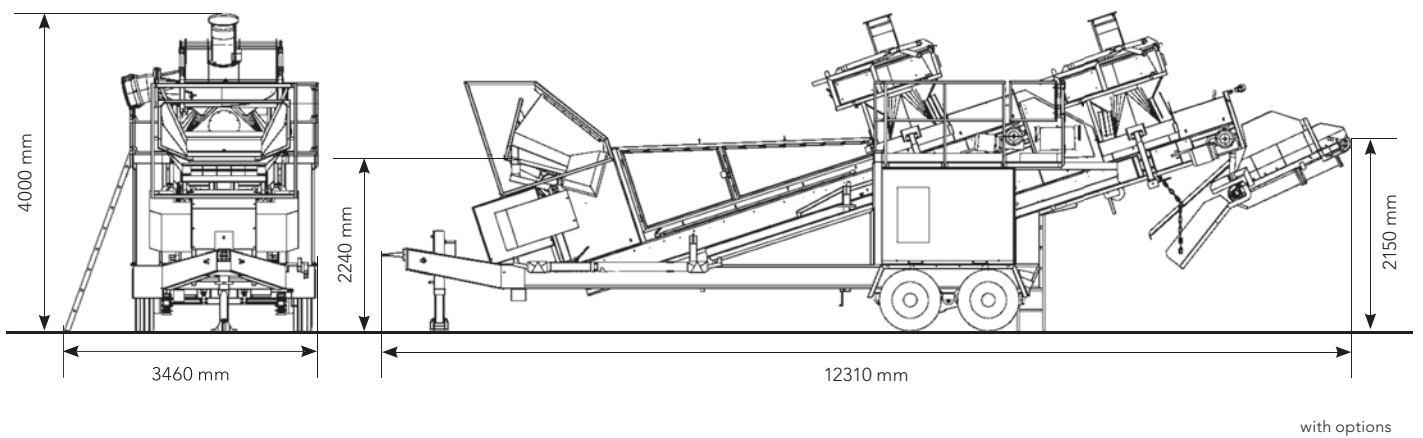

# STONEFEX

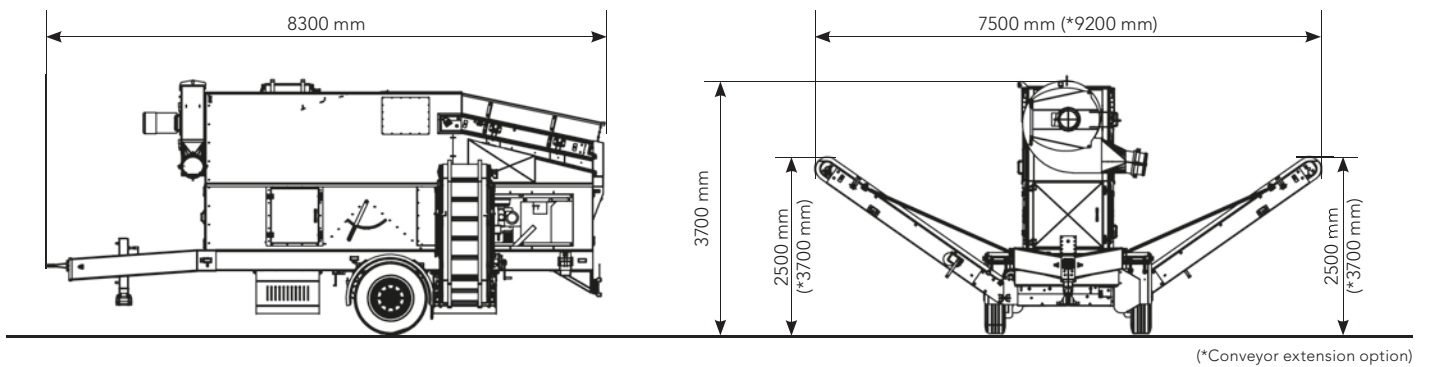

# HURRIFEX

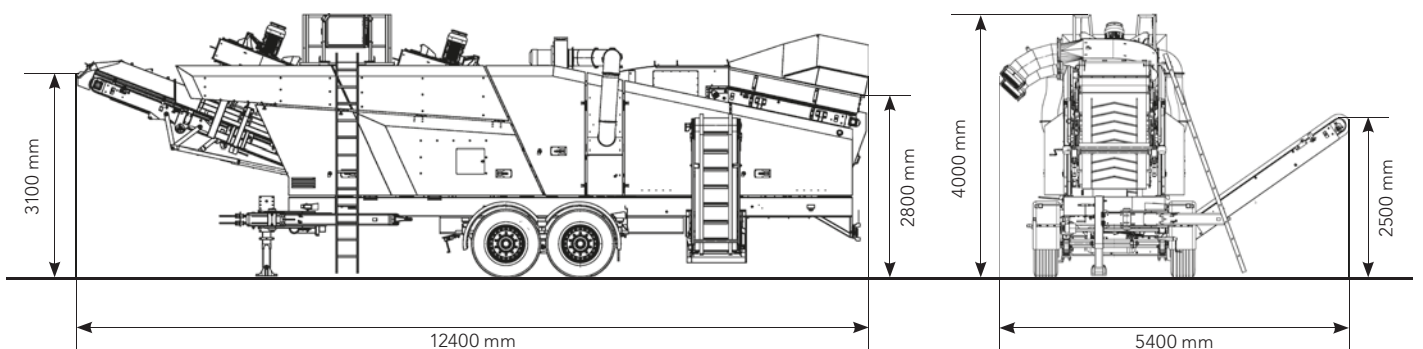

# TECHNOLOGY FOR A BETTER **ENVIRONMENT**



Komptech GmbH  
Kühau 37, A-8130 Frohnleiten, Austria  
[t] +43 3126 505 - 0  
[f] +43 3126 505 - 505  
[e] info@komptech.com

[www.komptech.com](http://www.komptech.com)

We reserve the right to make technical changes in the course of ongoing development. E2018